

发动机及化油器 Engine and Carburator

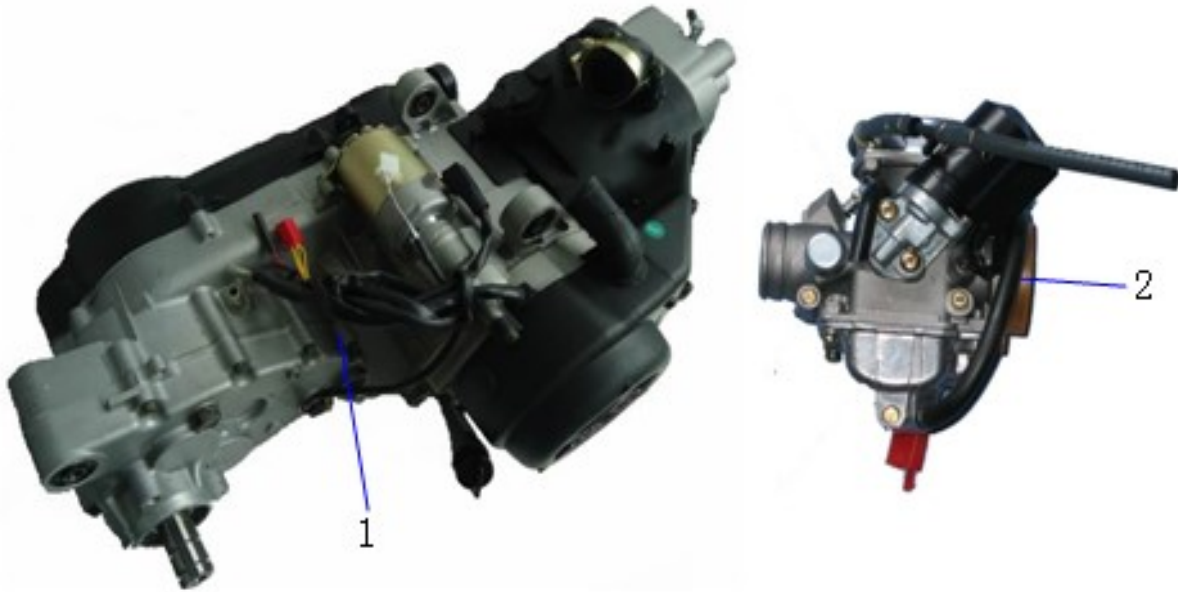

序	件号	中文名称	英文名称	数量		单价	
NO	Code name	Chinese	Description	Q'ty	¥	\$	
1	01010002	发动机 (170-B2)	Engine	1			
2	01030012	化油器 (170-A)	Carburator	1			

曲轴箱总成(一) Crankcase Assy

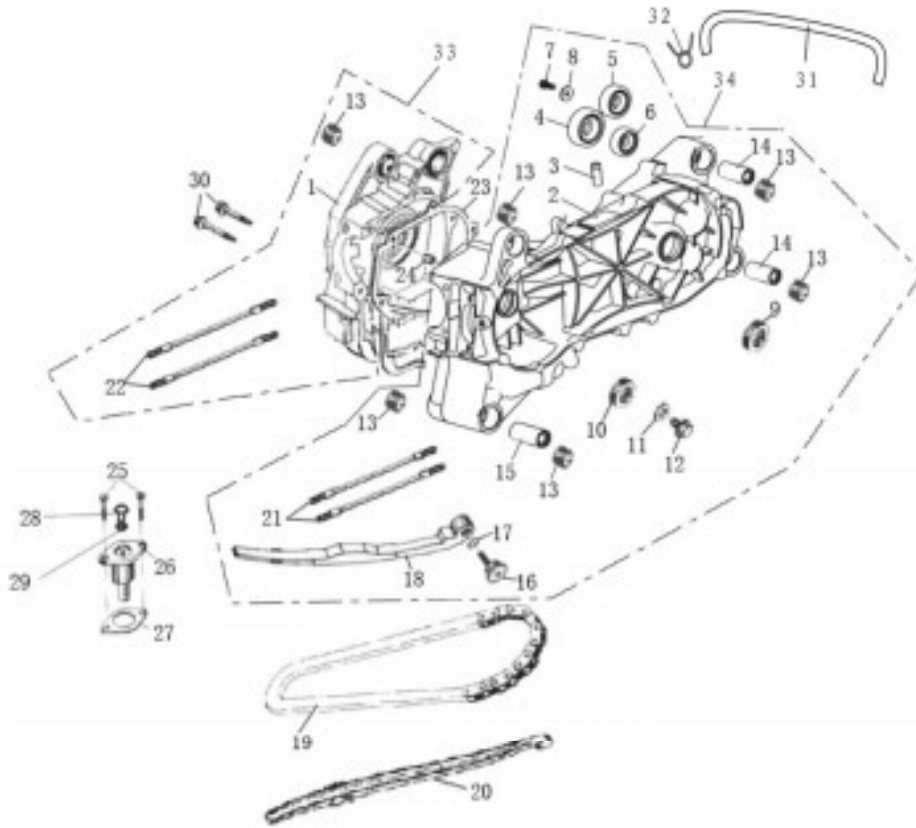

序	件号	中文名称	英文名称	数量	单价	
NO	Code name	Chinese	Description	Q'ty	¥	\$
1	2. 20. 05. 09. 02000	右箱体	R.Crankcase Assembly	1		
2	2. 20. 04. 66. 07000	左箱体本体总成	L.Crankcase Assembly	1		
3	1. 20. 07. 32. 12000	通气管接头	Breather Pipe Joint	1		
4	1. 00. 01. 6204	轴承6204	Bearing 6204	1		
5	1. 00. 01. 6203	轴承6203	Bearing 6203	1		
6	1. 00. 01. 6202	轴承6202	Bearing 6202	1		
7	1. 05. 01. 09. 0612	螺栓M6×12	Bolt M6×12	1		
8	1. 20. 20. 20. 17000	大垫圈6	Washer 6	1		
9	1. 20. 20. 01. 08000	输入轴油封20×32×6	Oil-Seal 20×32×6	1		
10	1. 20. 04. 01. 13000	曲轴油封19.8×30×5	Oil-Seal 19.8×30×5	1		
11	1. 20. 04. 01. 03000	平垫 12×18×1	Gasket 12×18×1	1		
12	1. 20. 04. 01. 14000	放油螺栓M12×1.5×14	Bolt M12×1.5×14	1		
13	1. 20. 04. 01. 09000	前减震套	Front Shock Absorber Sheath	5		
14	1. 20. 04. 65. 15000	衬套42	Bush 42	2		
15	1. 20. 04. 65. 16000	衬套50	Bush 50	1		
16	1. 20. 13. 01. 01000	固定拉力杆螺钉	Screw	1		
17	1. 20. 13. 01. 02000	O形圈16×1.5	O-Ring 16×1.5	1		
18	1. 20. 13. 01. 05000	拉力杆	Tension Rod	1		

19	1. 20. 13. 32. 04000	正时链条	Timing Chain	1		

曲轴箱总成 (二) Crankcase Assy

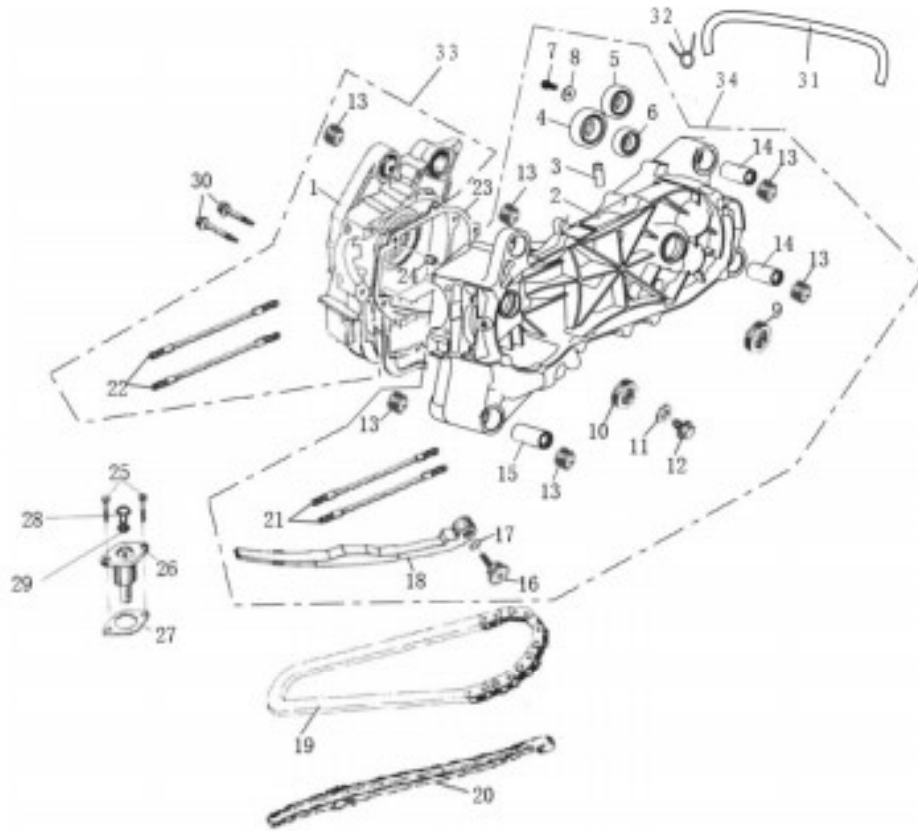

序	件号	中文名称	英文名称	数量	单价	
NO	Code name	Chinese	Description	Q'ty	¥	\$
20	1. 20. 13. 01. 06000	分气链条导件	Chain Guide	1		
21	1. 20. 04. 06. 04000	双头螺柱M8×209	Stud bolt M8×209	2		
22	1. 20. 05. 06. 01000	双头螺柱M8×201	Stud bolt M8×201	2		
23	1. 20. 04. 01. 05000	右箱体垫	Gasket	1		
24	1. 20. 04. 01. 01000	定位套 ø8×14	Locating Bush ø8×14	2		
25	1. 05. 01. 09. 0622	螺栓M6×22	Bolt M6×22	2		
26	1. 20. 13. 01. 07000	压链器	Chain Adjuster	1		
27	1. 20. 13. 01. 03000	压链器纸垫	Gasket	1		
28	1. 20. 13. 01. 08000	扁头螺钉	Screw	1		
29	1. 20. 13. 01. 09000	O形圈9.5*1.5	O-Ring 9.5*1.5	1		
30	1. 05. 01. 09. 0650	螺栓M6×50	Bolt M6×50	2		
31	1. 20. 04. 65. 12000	变速箱通风管	Gearcase Breather Pipe	1		
32	1. 20. 04. 65. 17000	卡箍11.5	Clamp 11.5	1		
33	2. 20. 05. 67. 99000	右箱体总成	R.Crankcase Assembly	1		
34	2. 20. 04. 66. 99000	左箱体总成	L.Crankcase Assembly	1		

变速箱盖总成(一) Gearcase Assy

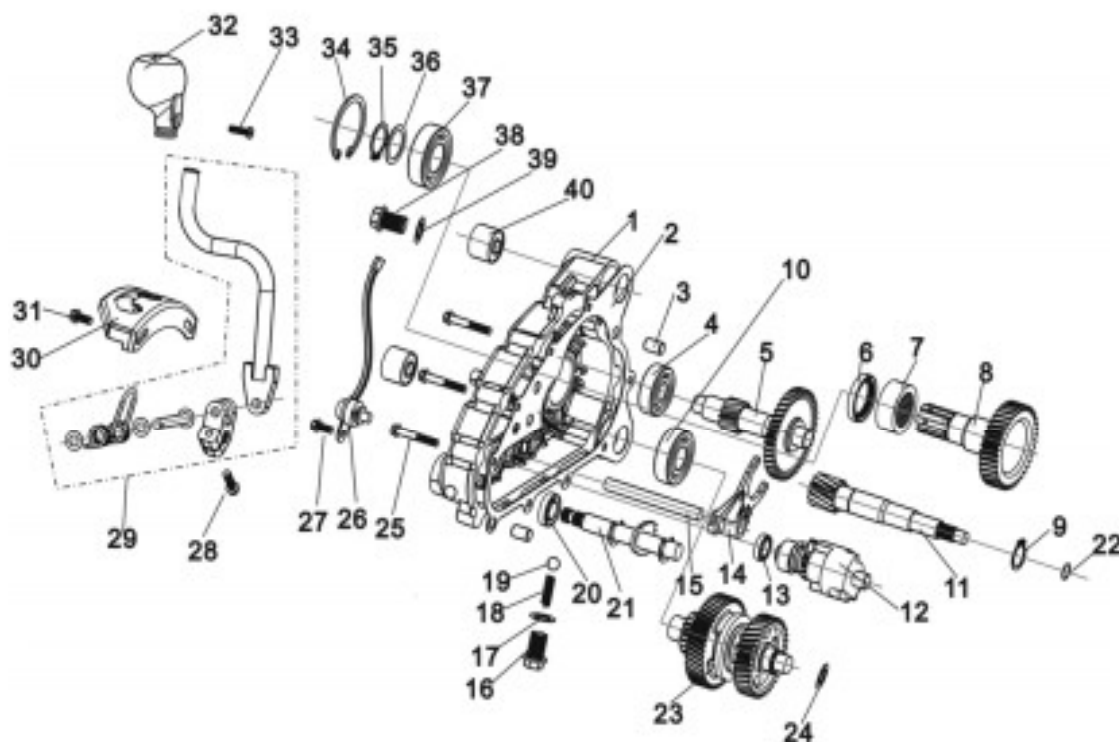

序 NO	件号 Code name	中文名称 Chinese	英文名称 Description	数量 Q'ty	单价	
					¥	\$
1	2. 20. 20. 65. 01000	变速箱盖	Gearcase cover	1		
2	1. 20. 20. 65. 08000	变速箱盖垫片	Gearcase Gasket	1		
3	1. 20. 01. 01. 01000	定位套	Locating Bush	2		
4	1. 00. 01. 6302	轴承6302	Bearing 6302	1		
5	1. 20. 20. 65. 10000	倒档齿轮轴组	Reverse Gear Shaft Assy	1		
6	1. 20. 20. 65. 14000	输出轴油封	Oil Seal of Output Shaft	1		
7	1. 00. 01. 4905	滚针轴承RNA4905	Needle Bearing RNA4905	1		
8	1. 20. 20. 65. 03000	输出轴	Output Shaft	1		
9	1. 05. 06. 02. 2000	轴用挡圈20	Check Ring 20	1		
10	1. 00. 01. 6204	轴承6204	Bearing 6204	2		
11	1. 20. 20. 65. 02000	变速箱输入轴	Input Shaft	1		
12	1. 20. 20. 65. 18000	变档鼓组件	Shift Drum Assy	1		
13	1. 20. 20. 65. 19000	变档鼓油封	Oil Seal	1		
14	1. 20. 20. 65. 11000	拨叉	Shift Fork	1		
15	1. 20. 20. 65. 21000	拨叉轴	Shift Rail	1		

16	1.20.04.65.18000	空心螺栓	Hollow Bolt	1		
17	1.20.04.65.19000	垫圈14×22×1	Washer 14×22×1	1		
18	1.20.04.65.20000	限位弹簧	Limit Spring	1		
19	1.20.04.65.21000	钢球13/32	Steel Ball	1		

变速箱盖总成 (二) Gearbox Cover Assy

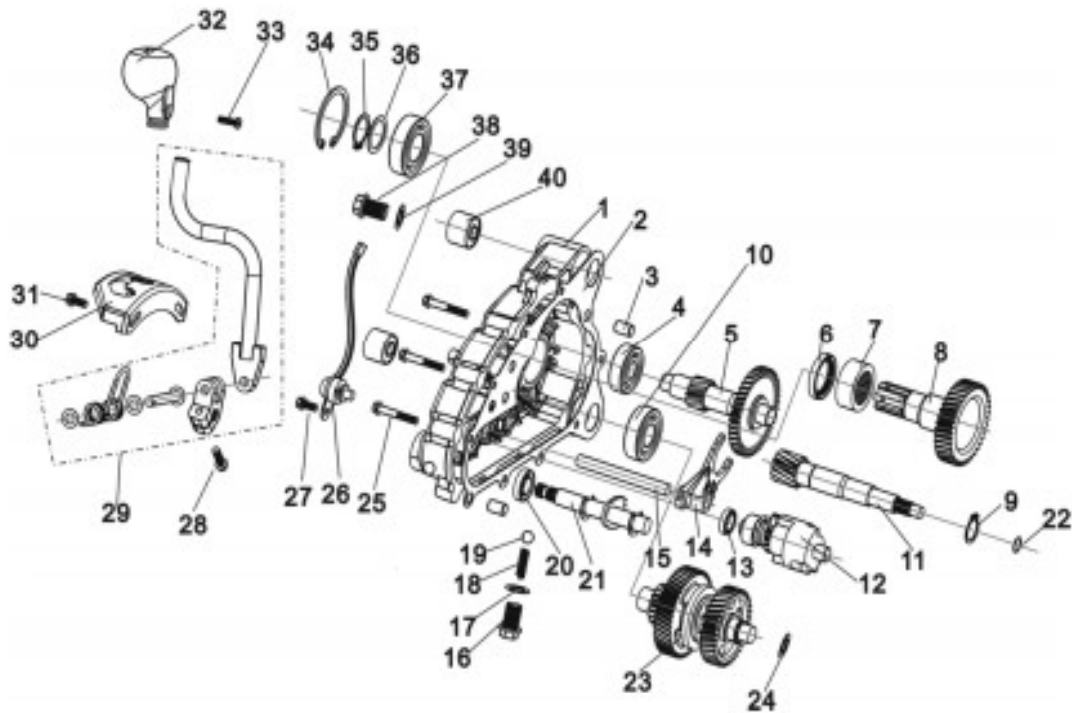

序	件号	中文名称	英文名称	数量	单价	
NO	Code name	Chinese	Description	Q'ty	¥	\$
20	1.20.20.65.16000	换档轴油封	Oil Seal of Shift Shaft	1		
21	1.20.20.65.17000	换档轴组件	Shift Shaft Assy	1		
22	1.20.20.65.20000	O形圈10×2.5	O-Ring 10×2.5	1		
23	1.20.20.65.09000	中间齿轮轴组	Intermediate Gear Shaft	1		
24	1.20.04.65.23000	垫圈15×19×1	Washer 15×19×1	1		
25	1.05.01.09.0640	螺栓M6×40	Bolt M6×40	10		
26	1.20.32.65.08000	档位传感器组件	Gear Sensor Module	1		
27	1.05.01.09.0612	螺栓M6×12	Bolt M6×12	1		
28	1.05.01.08.0622	螺栓M6×22	Bolt M6×22	1		
29						
30						
31						
32						

33					
34	1.05.06.01.5200	孔用挡圈52	Check Ring 52	1	
35	1.05.06.02.2500	轴用挡圈25	Check Ring 25	1	
36	1.20.04.65.22000	垫圈25×33×1	Washer 25×33×1	1	
37	1.00.01.6205-2RS	轴承6205-2RS	Bearing 6205-2RS	1	
38	1.20.04.01.14000	放油螺栓M12×1.5×14	Bolt M12×1.5×14	1	
39	1.20.04.01.03000	平垫 12×18×1	Gasket 12×18×1	1	
40	1.20.04.01.09000	前减震套	Front Shock Absorber	2	

左盖总成 Left Cover Assy

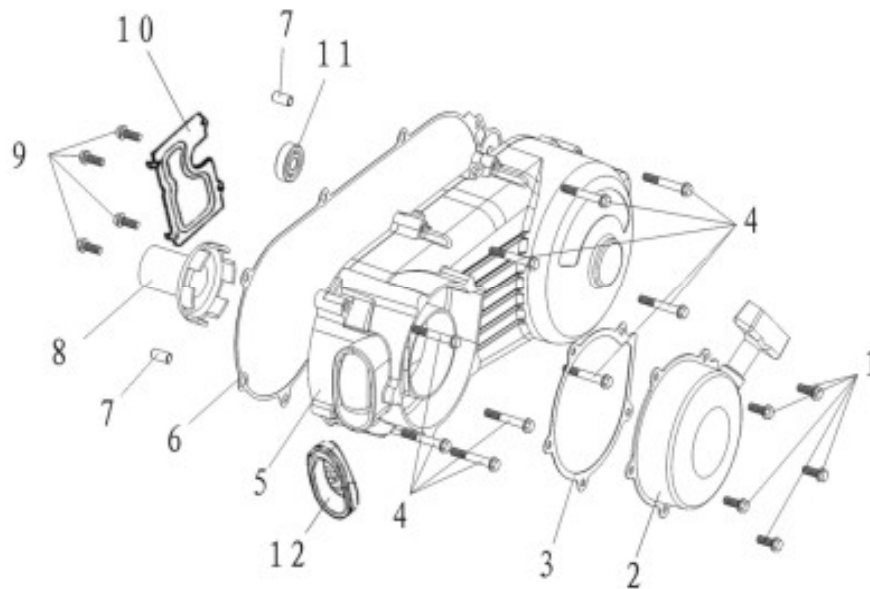

序	件号	中文名称	英文名称	数量	单价	
NO	Code name	Chinese	Description	Q'ty	¥	\$
1						
2						
3						
4	1.05.01.09.0640	螺栓M6×40	Bolt M6×40	8		
5	2.20.06.65.01001	左盖	Left Cover	1		
6	1.20.06.01.07000	左盖垫	Left Cover Gasket	1		
7	1.20.04.01.01000	定位套 ø8×14	Locating Bush ø8×14	2		
8						
9	1.05.02.03.4208	自攻螺钉ST4.2×8	Tapping Screw ST4.2×8	4		
10	1.20.06.01.03000	通气导板	Breather Guide Plate	1		
11	1.00.01.6200-2RS	轴承6200-2RS	Bearing 6200-2RS	1		
12	1.20.06.01.10001	吸风口罩	Cover of Exhaust Opening	1		

右箱体端盖总成 Right Cover Assy

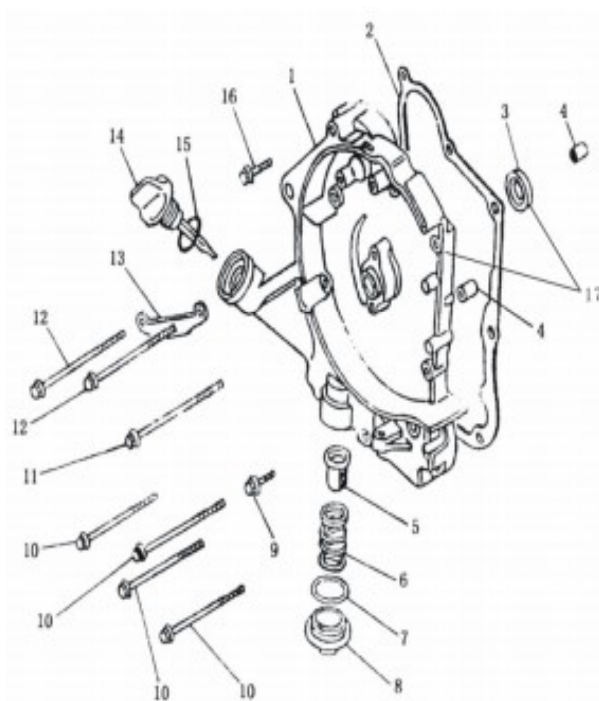

序	件号	中文名称	英文名称	数量	单价	
NO	Code name	Chinese	Description	Q'ty	¥	\$
1	2. 20. 07. 01. 01000	右盖	Right Cover	1		
2	1. 20. 07. 01. 06000	右盖垫	Right Cover Gasket	1		
3	1. 20. 04. 01. 13000	曲轴油封19.8×30×5	Oil Seal 19.8×30×5	1		
4	1. 20. 04. 01. 01000	定位套φ8×14	Locating Bush φ8×14	2		
5	1. 20. 07. 01. 09000	滤油网	Oil-Filter Screen	1		
6	1. 20. 07. 01. 03000	滤油网弹簧	Oil-Filter Screen Spring	1		
7	1. 20. 07. 01. 04000	O形圈30.5×3	O-Ring 30.5×3	1		
8	1. 20. 07. 01. 02000	滤油网螺帽	Oil-Filter Screen Nut	1		
9	1. 05. 01. 09. 0632	螺栓M6×32	Bolt M6×32	1		
10	1. 05. 01. 09. 0695	螺栓M6×95	Bolt M6×95	4		
11	1. 05. 01. 09. 06100	螺栓M6×100	Bolt M6×100	1		
12	1. 05. 01. 09. 06110	螺栓M6×110	Bolt M6×110	2		

13	1. 20. 07. 01. 08000	触发线卡	Trigger Line Card	1		
14	1. 20. 07. 01. 05000	机油尺	Oil Level Gauge	1		
15	1. 20. 07. 01. 07000	O形圈18×3	O-Ring 18×3	1		
16	1. 05. 01. 09. 0635	螺栓M6×35	Bolt	1		
17	2. 20. 07. 01. 99000	右盖总成	Right Cover Assy	1		

气缸体总成 Cylinder Body Assy

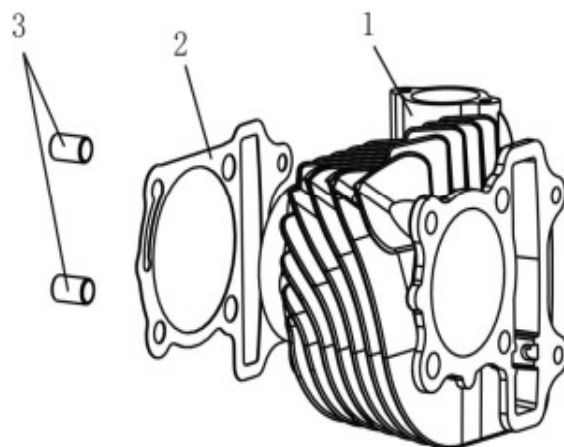

序	件号	中文名称	英文名称	数量	单价	
NO	Code name	Chinese	Description	Q'ty	¥	\$
1	1. 20. 02. 09. 03000	气缸体	Cylinder Block	1		
2	1. 20. 02. 09. 01000	气缸垫	Cylinder Block Gasket	1		
3	1. 20. 01. 01. 01000	定位套φ10×16	Locating Bush φ10×16	2		

气缸头总成 Cylinder Head Assy

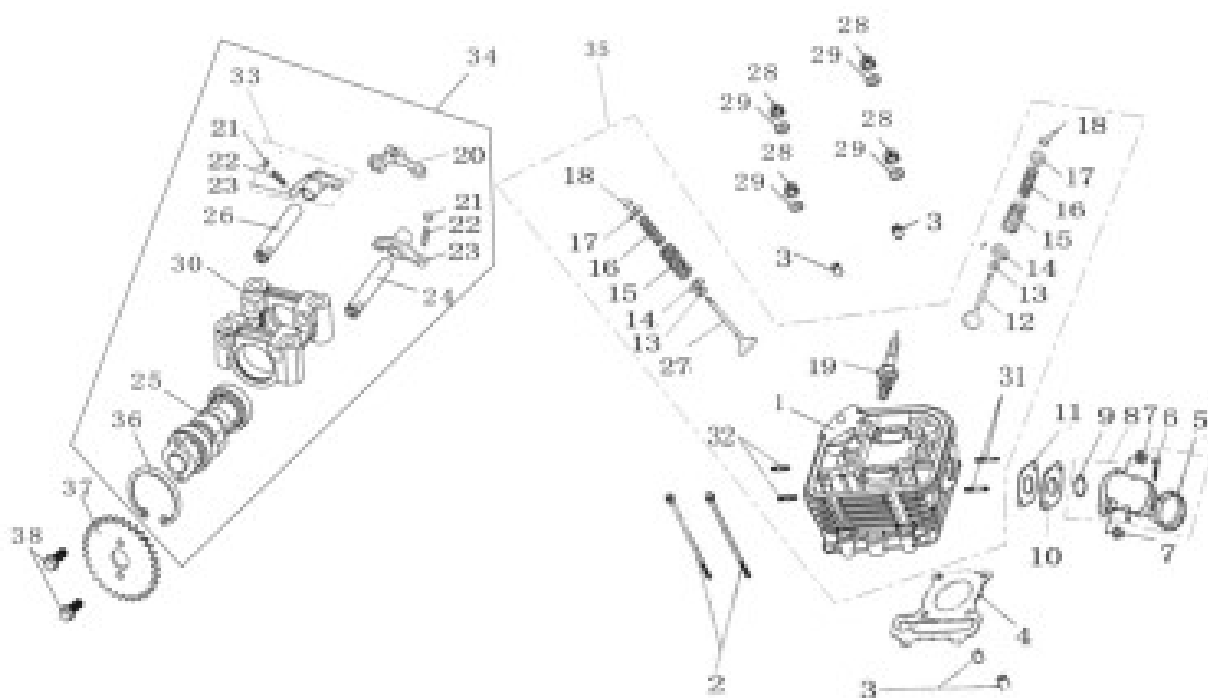

序 NO	件号 Code name	中文名称 Chinese	英文名称 Description	数量 Q'ty			单价 Unit Price	
				数量	¥	\$	¥	\$
1	2. 20. 01. 09. 13000	气缸头组本体 (无补气)	Cylinder Head	1				
2	1. 05. 01. 09. 06100	螺栓M6×100	Bolt M6×100	2				
3	1. 20. 01. 01. 01000	定位套 φ10×16	Locating Bush φ10×16	4				
4	1. 20. 01. 09. 15000	气缸头垫片	Cylinder Head Gasket	1				
5	1. 20. 01. 01. 16010	进气管夹	Pipe Clamp	1				
6	1. 05. 02. 01. 0425	螺钉M4×25	Screw M4×25	1				
7	1. 05. 04. 02. 0600	螺母M6	Nut M6	2				
8	1. 20. 01. 01. 16000	进气管总成	Intake-Tube Assy	1				
9	1. 00. 14. 265180	O形圈26.5×1.8	O-Ring 26.5×1.8	1				
10	1. 20. 01. 01. 12000	化油器隔热板	Thermal Baffle	1				

11	1.20.01.01.11000	(隔热板)纸垫板	Base Plate	1		
12	1.20.01.06.06000	进气门	Inlet Valve	1		
13	1.20.01.01.14000	气门油封	Valve Oil Seal	2		
14	1.20.01.01.10000	(气门弹簧)垫片	Gasket	2		
15	1.20.01.06.09000	气门外弹簧	Outer Valve Spring	2		
16	1.20.01.06.08000	气门内弹簧	Inner Valve Spring	2		
17	1.20.01.01.05000	气门弹簧座	Valve Spring Retainer	2		
18	1.20.01.01.07000	气门锁块	Valve Cotter	4		
19	1.20.01.01.17000	火花塞	Spark Plug	1		
20	1.20.12.01.05000	止动板组	Stop Plate	1		
21	1.20.12.01.04020	调整螺母	Adjusting Nut	2		
22	1.20.12.01.04030	调整螺丝	Adjusting Screw	2		
23	1.20.12.06.04010	(气门)摇臂	Rocker Arm	2		

气缸头总成 (二) Cylinder Head Assy

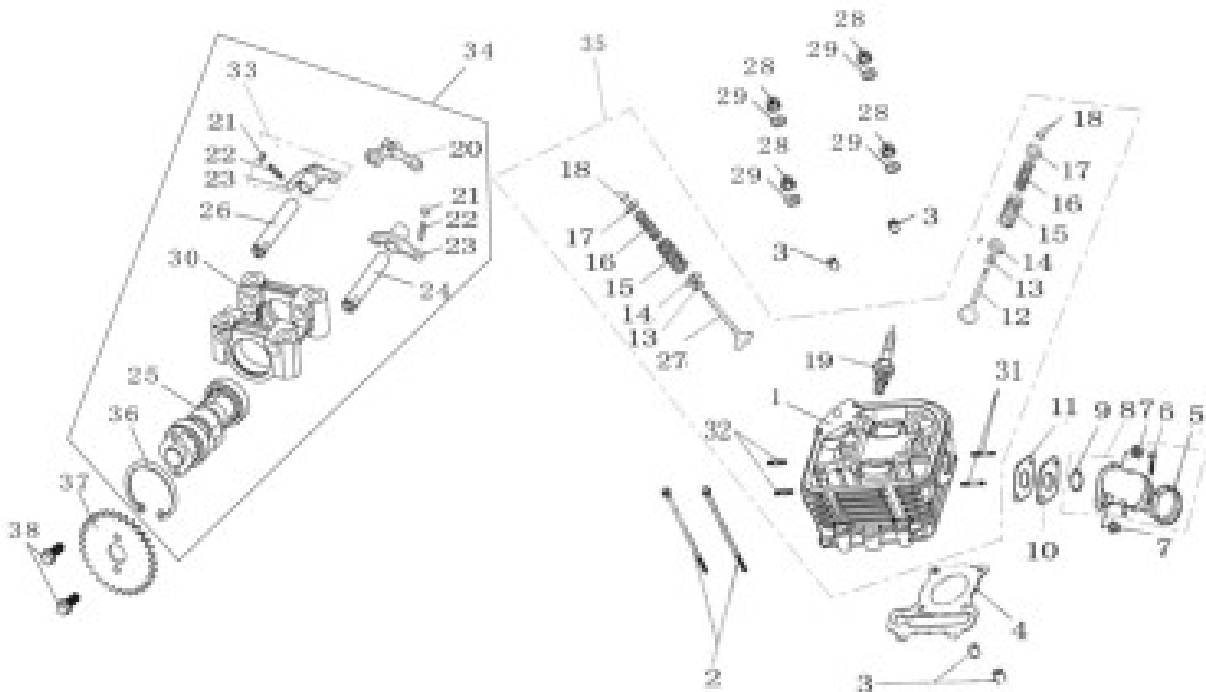

序	件号	中文名称	英文名称	数量	单价	
NO	Code name	Chinese	Description	Q'ty	¥	\$
24	1.20.12.06.03000	进气摇臂轴组	Inlet Rocker Arm Shaft Assy	1		
25	1.20.11.06.01000	凸轮轴总成	Camshaft Assy	1		
26	1.20.12.06.02000	排气摇臂轴	Inlet Rocker Arm Shaft	1		
27	1.20.01.06.04000	排气门	Exhaust Valve	1		
28	1.05.04.02.0800	螺母M8	Nut M8	4		
29	1.20.04.01.06000	垫圈8	Washer 8	4		

30	2. 20. 12. 06. 01000	凸轮轴座	Camshaft Retainer	1		
31	1. 20. 01. 01. 03000	双头螺柱M6×63	Stud Bolt M6×63	2		
32	1. 20. 01. 08. 02000	双头螺柱M8×32	Stud Bolt M8×32	2		
33	1. 20. 12. 06. 04000	气门摇臂	Valve Rocker	2		
34	2. 20. 12. 06. 99000	凸轮轴座总成	Camshaft Retainer Assy	1		
35	2. 20. 01. 67. 99000	气缸头总成	Cylinder Head Assy	1		
36	1. 05. 06. 01. 3500	孔用挡圈35	Check Ring	1		
37	1. 20. 11. 32. 02000	正时链轮	Timing Sprocket	1		
38	1. 05. 01. 08. 0512	螺栓M5×12	Bolt M5×12	2		

气缸头盖总成 Cylinder Head Cover Assy

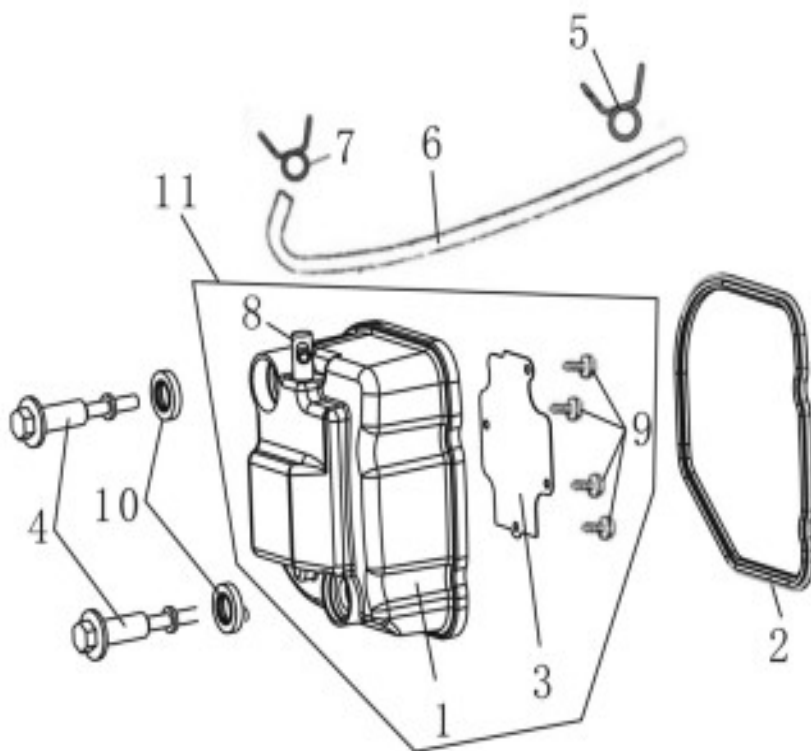

序	件号	中文名称	英文名称	数量	单价	
NO	Code name	Chinese	Description	Q'ty	¥	\$

1	2.20.03.06.01000	气缸头盖	Cylinder Head Cover	1		
2	1.20.03.06.03000	气缸盖密封圈	Seal Ring of Cylinder Head Cover	1		
3	1.20.03.01.02008	盖片	Cover Slip	1		
4	1.20.03.32.30000	盖罩螺栓	Bolt	2		
5	1.20.03.01.05010	管夹	Pipe Clamp	1		
6	1.20.03.01.05000	通气管组	Breather Pipe Assy	1		
7	1.20.03.01.05020	管夹	Pipe Clamp	1		
8	1.20.03.01.04000	管接头组件	Pipe Joint Assy	1		
9	1.05.02.03.4208	自攻螺钉ST4.2×8	Tapping Screw ST4.2×8	4		
10	1.20.03.32.31000	衬胶垫圈	Rubber Gasket	2		
11	2.20.03.06.99000	气缸头盖总成	Cylinder Head Cover Assy	1		

曲轴连杆组件、活塞组件 Connecting Rod of Crank-shaft Assy

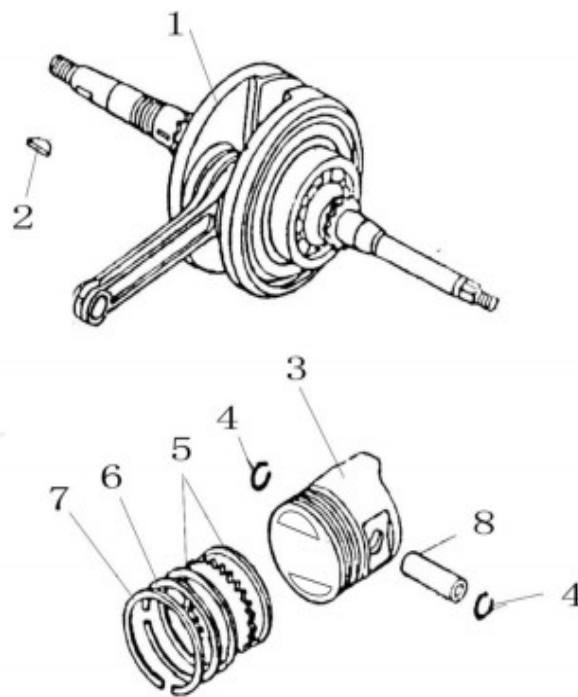

序	件号	中文名称	英文名称	数量	单价
---	----	------	------	----	----

NO	Code name	Chinese	Description	Q'ty	¥	\$
1	1. 20. 09. 65. 01000	曲轴连杆组	Connecting Rod of Crank-shaft	1		
2	1. 20. 09. 01. 01010	半圆键	Woodruff Key	1		
3	1. 20. 10. 08. 01000	活塞	Piston	1		
4	1. 20. 10. 01. 04000	活塞销卡簧	Clamp Spring	2		
5	1. 20. 10. 08. 02000	油环组合(含刮片环)	Oil Ring	1		
6		第二道气环	Piston Ring 1			
7		第一道气环	Piston Ring 2			
8	1. 20. 10. 08. 03000	活塞销	Piston Pin	1		

起动电机总成 Starting Motor Assy

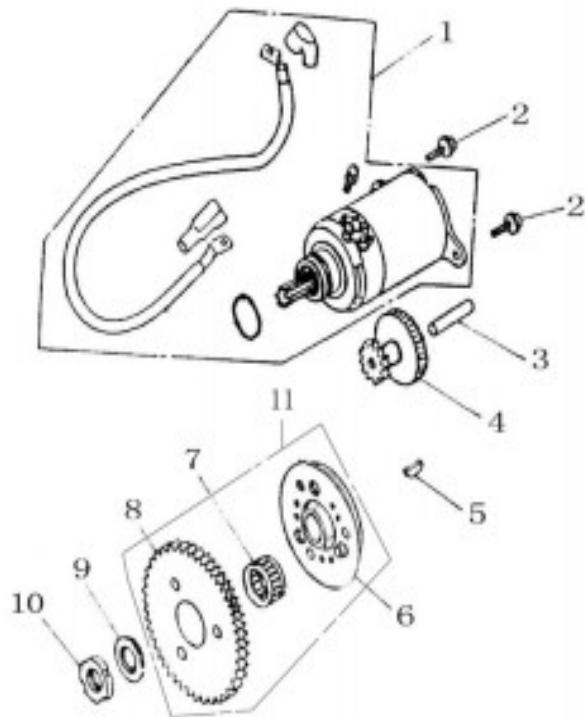

序	件 号	中文名称	英文名称	数量	单价
---	-----	------	------	----	----

NO	Code name	Chinese	Description	Q'ty	¥	\$
1	1. 20. 18. 01. 01000	起动电机总成	Starter Motor Assy	1		
2	1. 05. 01. 09. 0616	螺栓M6×16	Bolt M6×16	2		
3	1. 20. 18. 01. 02000	齿轮轴	Gear Shaft	1		
4	1. 20. 18. 01. 03000	过渡齿轮	Transition Gear	1		
5	1. 20. 09. 01. 01010	半圆键	Woodruff Key	1		
6	1. 20. 19. 08. 01020	超越离合器组件	OVERRUNNING COUPLER ASSY	1		
7	1. 20. 19. 01. 01040	滚针轴承	Needle Bearing	1		
8	1. 20. 19. 03. 01030	从动齿轮组合	Driven Gear Assy	1		
9	1. 20. 19. 01. 03000	垫片	Gasket	1		
10	1. 20. 19. 01. 02000	锁紧螺母SM22×1左	Locknut SM22×1 (L.)	1		
11	1. 20. 19. 08. 01000	起动超越离合器	OVERRUNNING COUPLER	1		

主、从动皮带轮总成 Driving and Driven Pulley Assy

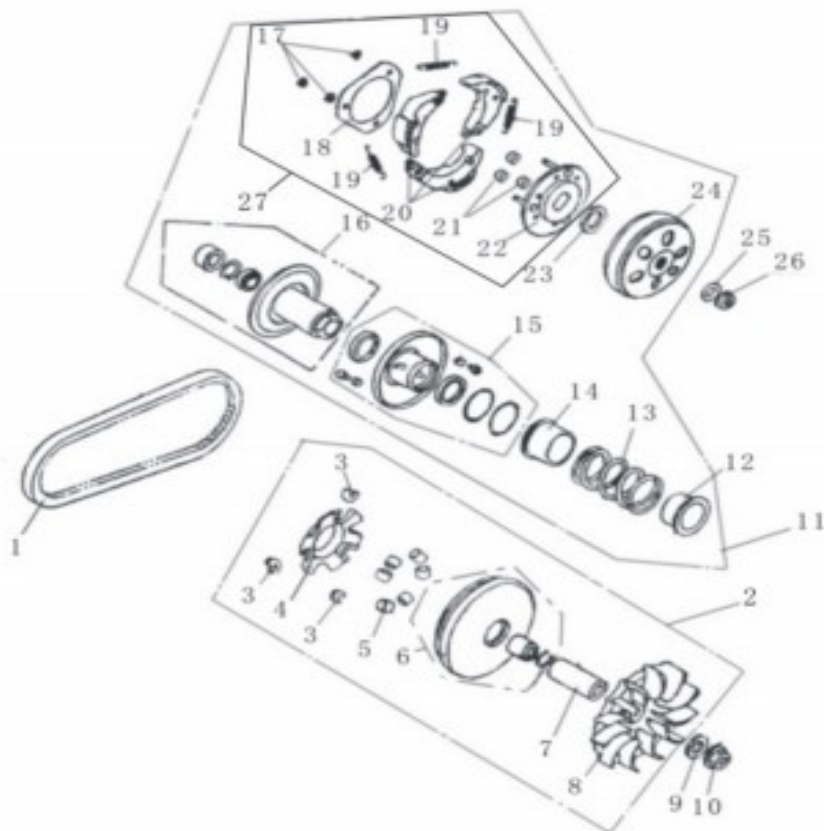

序	件号	中文名称	英文名称	数量	单价	
NO	Code name	Chinese	Description	Q'ty	¥	\$
1	152019000	齿形三角皮带743-20-30	Tooth Belt	1		
2	1.20.21.01.01000	主动皮带轮总成	Driving Pulley Assy	1		
3	1.20.21.01.01060	琅块	Piece	3		
4	1.20.21.01.01050	拖动法兰	Drag Flange	1		
5	1.20.21.01.01040	离心滚柱	Right Capstan Assy	6		
6	1.20.21.01.01030	右主动轮组合	Right Capstan Assy	1		
7	1.20.21.01.01020	衬套	Bush	1		
8	1.20.21.01.01010	驱动皮带扇叶盘	Driving Belt Fan	1		
9	1.20.17.65.03001	垫圈12.5×25×7	Washer 12.5×25×7	1		
10	1.05.04.10.1213	螺母M12×1.25 H=10	Nut M12×1.25 H=10	1		
11	1.20.22.01.01000	从动皮带轮总成	Follower Pulley Assy	1		
25	1.05.05.04.1200	垫圈12.3×29×2.5	Washer 12.3×29×2.5	1		
26	1.05.04.10.1212	螺母M12×1.25 H=8	Nut M12×1.25 H=8	1		

磁电机部件、机油泵部件 Magneto and Oil pump

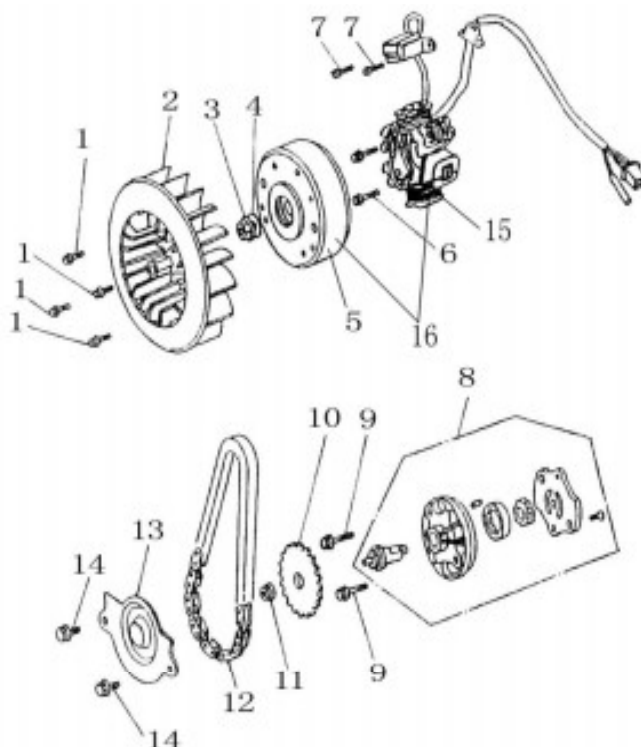

序	件号	中文名称	英文名称	数量	单价	
NO	Code name	Chinese	Description	Q'ty	¥	\$
1	1.05.01.09.0618	六角法兰面螺栓M6×18	Hexagon Bolt M6×18	4		
2	1.20.24.01.06000	风扇组合	Fan Assy	1		
3	1.05.04.10.1213	螺母M12×1.25 H=10	Nut M6 M12×1.25 H=10	1		
4	1.05.05.04.1201	平垫12-14HV	Flat Gasket 12-14HV	1		
5	1.20.16.01.01022	飞轮（直流11级）	Rotor Assy (DC 11)	1		
6	1.05.01.09.0620	六角法兰面螺栓M6×20	Hexagon Bolt M6×20	2		
7	1.05.01.08.0512	六角螺栓M5×12	Hexagon Bolt M5×12	2		
8	1.20.14.01.03000	机油泵组合	Oil Pump Assy	1		
9	1.05.01.09.0625	螺栓M6×25	Bolt M6×25	2		
10	1.20.14.01.01000	油泵链轮	Oil Pump Sprocket Wheel	1		
11	1.05.04.02.0600	螺母M6	Nut M6	1		
12	1.20.14.01.04000	油泵链条	Oil Pump Chain	1		
13	1.20.14.01.02000	链轮端盖	Sprocket Wheel End Cap	1		
14	1.05.01.09.0612	螺栓M6×12	Bolt M6×12	2		
15	1.20.16.01.01012	定子组件（直流11级）	Stator Assy (DC 11)	1		
16	1.20.16.01.01002	磁电机总成（直流11	Magnetor Assy (DC 11)	1		

导风罩 Fan Cover Assy

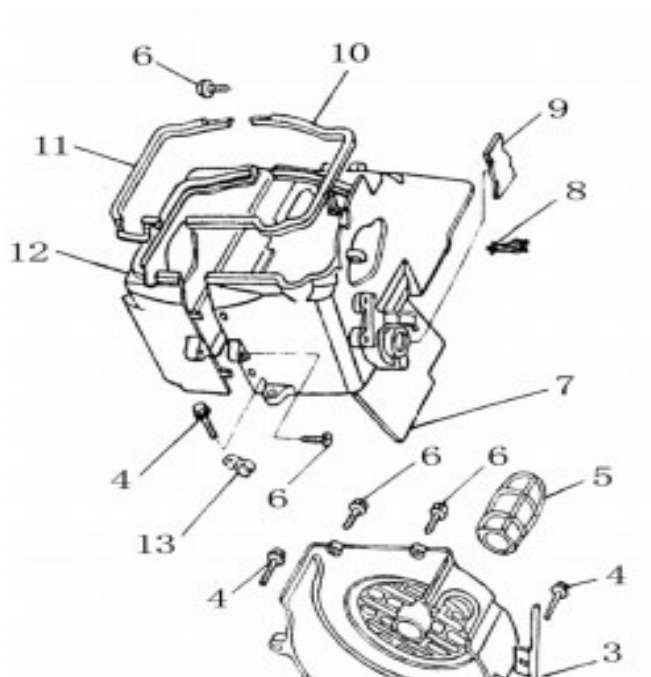



序 NO	件号 Code name	中文名称 Chinese	英文名称 Description	数量 Q'ty	单价 ¥ \$	
1	1. 20. 24. 03. 03000	风扇盖	Fan cover	1		
2	1. 20. 24. 01. 03020	窗口堵盖	Blanking Cap	1		
3	1. 20. 24. 01. 04000	电缆线夹	Cable Clamp	1		
4	1. 05. 01. 09. 0625	螺栓M6×25	Bolt M6×25	3		
5	1. 20. 24. 01. 03010	冷却导管	Cooling Duct	1		
6	1. 05. 02. 15. 4816	自攻螺钉ST4.8×16-F-	Tapping Screw ST4.8×16-F-H	5		
7	1. 20. 24. 06. 01020	161-B2上导风罩组件	Upper Fan Cover Assy	1		
8	1. 20. 24. 01. 01040	高压线夹	Cable Clamp	1		
9	1. 20. 24. 01. 01030	橡胶盖	Rubber Cover	1		
10	1. 20. 24. 01. 01010	161-B2上密封胶垫	Upper Rubber Mat	1		
11	1. 20. 24. 01. 02020	161-B2下密封胶垫	Lower Rubber Mat	1		
12	1. 20. 24. 06. 02000	161-B2下导风罩组合	Lower Fan Cover Assy	1		
13	1. 20. 24. 01. 05000	溢流管夹	Tubing Clamp	1		

车架/车架附件 Frame and accessories





序	件号	中文名称	英文名称	数量	单价	
NO	Code name	Chinese	Description	Q'ty	¥	\$
1	0201-200GKV	车架	Frame	1		
2	02010761	棚架中	Top Roof(Middle)	1		
3	02010767	前护杠	Front guard	1		
4	02010764	前棚架左	Front frame L.	1		
5	02010765	前棚架右	Front frame R.	1		
6	02010769	扶手左	Handrail L.	1		
7	02010770	扶手右	Handrail R.	1		
8	02010758	后护杠	Rear guard	1		
9	02010768	棚架连接管	Top Light bracket	1		
10	02010801	刹车踏板组件	Brake Pedal assy	1		
11	02010802	油门踏板组件	Accelerator Pedal assy	1		
12	02010833	棚架中间连接件	Connecting piece	1		
13	02010762	后棚架左	Rear frame L.	1		
14	02010763	后棚架右	Rear frame R.	1		
15	02010744	油箱卡箍小	Fuel tank clamp (Small)	1		
16	02010743	油箱卡箍大	Fuel tank clamp (Big)	1		
17	02030164	方向柱(管柱)	Direction Column	1		
18	02010928	备胎架	Spare Wheel Carrier	1		
19	02010231	装饰灯支架	Top Light bracket	1		

车架附件 Frame accessories





序	件号	中文名称	英文名称	数量	单价	
NO	Code name	Chinese	Description	Q'ty	¥	\$
1	02010754	后托架	Rear Axle Bracket Assy	1		
2	02010756	消声器支架	Muffler Bracket	1		
3	02010771	右坐垫安装支架	Mounting bracket for right seat	1		
4	02011273	上摇臂组件左	Upper Rocker Arm(Left)	1		
5	02011274	上摇臂组件右	Upper Rocker Arm(Right)	1		
6	02011275	下摇臂组件左	Lower Rocker Arm(Left)	1		
7	02011276	下摇臂组件右	Lower Rocker Arm(Right)	1		
8	02010759	把手支架	Handlebar support	1		
9	02010760	手把管	Handlebar	1		
10	02010739	踏板支架	Footrest support	1		
11	02010757	坐垫后支架	Rear support of Seat	1		
12	05020009	坐垫滑轨	Seat Slide Rail	1付		
13	02010740	变档手柄 (变档杆组件)	Shifting Hand Shank	1		
14	02010746	调节固定板	Adjust fixed plate	1		
15	02010749	换挡摇臂	Shift rocker arm	1		
16	02010747	调节拉杆 (链条)	Control rod	1		
17	02010745	换挡拉线固定板	Fixed plate for Shift cable	1		
18	07990003	缓冲衬套 $\phi 30 * \phi 10 * 35$		2		
19	12060023	调节球头M14		2		

油箱、减震器、方向机 Fuel Tank, Shock



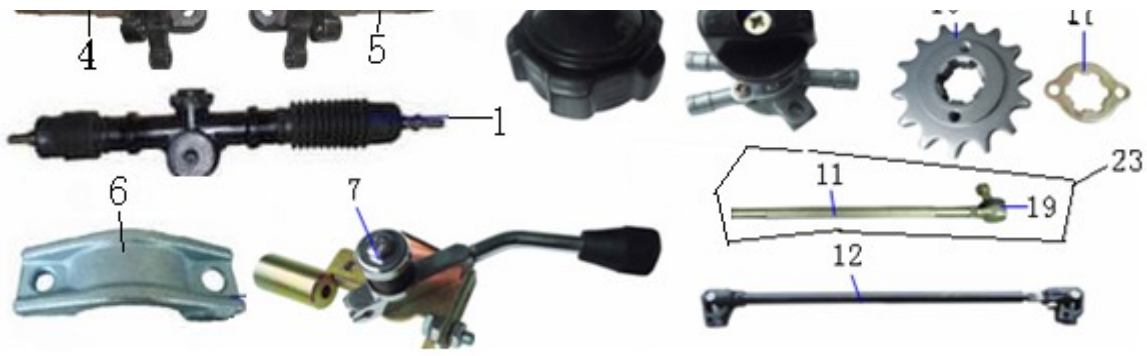

序	件号	中文名称	英文名称	数量	单价	
NO	Code name	Chinese	Description	Q'ty	¥	\$
1	02030269	方向机	Redirector	1		
2	07010120	前减震	Front Shock	2		
3	07010077	后减震	Rear Shock	2		
4	02030266	前转向角 (左)	Front Steering Angle L.	1		
5	02030267	前转向角 (右)	Front Steering Angle R.	1		
6	02011278	方向机压板	Redirector Fixed Plate	2		
7	04990006	手刹器	Hand Brake	1		
8	05030049	油箱	Fuel tank	1		
9	05050010	农夫车油箱盖	Cover of fuel tank	1		
10	10060014	油箱开关	Fuel tank switch	1		
11	190372	转向拉杆L:220MM	Turning Lever	2		
12	02030163	万向节	Cardan joint	1		
13	02030056	方向盘 (300)	Steering Wheel	1		
14	02040047	前轮毂座组件	Front Wheel Hub ASSY	2		
15	02010331	吊架衬管	Screened Pipe	1		
16	02040163	V250主动链轮530-12	V250 Drive Sprocket	1		
17	02010828	v250主动链轮固定片	V250 Locking Plate	1		
18	10040066	油位传感器	sensor	1		
19	12060019	M10*1.25锥度球头/倒	Ball Joint RH thread	2		
20						
21	12030023	轴承6203	Bearing 6203	2		
22	12030014	轴承6204	Bearing 6204	2		
23	02030268	转向拉杆 (带球头)	Steering rod with 1 ball Joint	2		
24	14010016	轮毂座	Wheel Hub	2		

后轴 Rear Axle

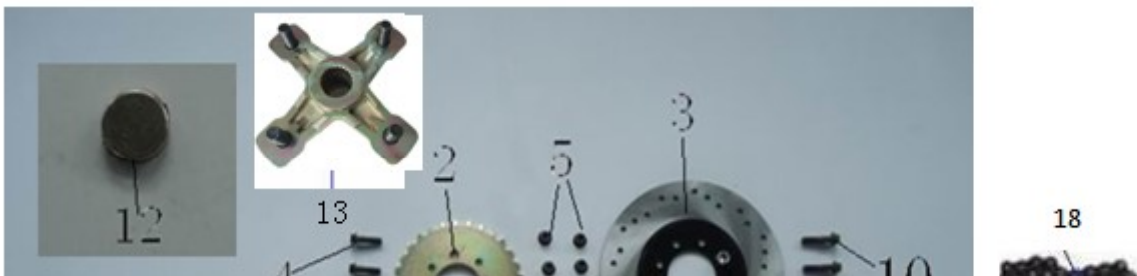

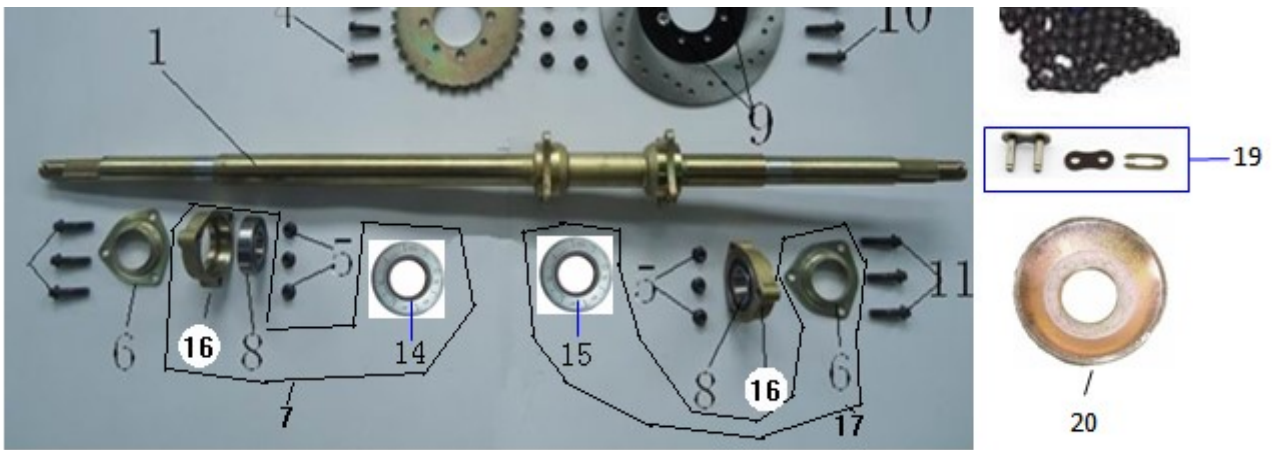

序	件号	中文名称	英文名称	数量	单价	
NO	Code name	Chinese	Description	Q'ty	¥	\$
1	02040048	后桥轴	Rear axle	1		
2	02040038	链盘(牙盘530-31)	Chain plate (530-31)	1		
3	04020009	(后)碟刹盘220*58	Rear brake disc(220*58)	1		
4	M8*30	六角法兰面螺栓	Hexagon bolt with flange (M8*30)			
5	M8*1.25	六角法兰面自锁螺母	Hexagon locking-nuts with flange (M8*1.25)			
6	02040009	轴承座防尘盖	Dust cap for the bearing pedestal	2		
7	02040051	轴承座组件	Bearing pedestal	2		
8	12030016	轴承6206	Bearing6206	2		
9	02010240	磁钢座	Magnetic steel seat	4		
10	M8*25	六角法兰面螺栓	Hexagon bolt with flange M8*25			
11	M8*40	六角法兰面螺栓	Hexagon bolt with flange M8*40			
12	10990004	磁钢	Magnetic steel	4		
13	02040105	后轮毂座组件	Rear hub seat	2		
14	12040014	油封 $\phi 50 \times \phi 34 \times 7$	Oil Seal $\phi 50 \times \phi 34 \times 7$	2		
15	12040015	油封 $\phi 42 \times \phi 30 \times 7$	Oil Seal $\phi 42 \times \phi 30 \times 7$	2		
16	02040008	轴承座	Bearing Seat	2		
17	02040198	轴承座防尘盖组件	Bearing Seat Dust Cover	2		
18	02040159	链条530	Chain 530	1		
19	02040160	530链条接头	Master Link 530	1		
20	02011053	碗形垫片	Bowl Gasket	2		

坐垫、空滤器、消声器 Seat, Air Filter





序	件号	中文名称	英文名称	数量	单价	
NO	Code name	Chinese	Description	Q'ty	¥	\$
1	12050014	轴用卡簧10	Circlip 10	1		
2	12050015	轴用卡簧12	Circlip 12	1		
3	01040012	空滤器	Air Filter	1		
4	01990001	二次补气装置	Twice Adding Air Instrument	1		
5	06030002	油管4.5X8.5	Oil Pipe 4.5X8.5	15		
6	190098	滤芯	Filter Element	1		
7	12010007	油管夹8.5	Pipeline clip 8.5	9		
8	07020079	刹车拉簧	Brake tension spring	1		
9	07020078	油门扭簧	Accelerator torsional spring	1		
10	01050032-1 XP	消声器	Muffler	1		
10.1	01050032-2	消声器前管	Exhaust pipe	1		
11	05020010	安全带(带螺栓)	Safety belt	2		
12	03030229	链罩	Chain guard	1		
13	05010037	坐垫	Seat	2		
14	12010020	油管夹10	Pipeline clip 10	1		
15	06020015	橡胶管塞38	Rubber cover 38	4		
16	06990001	二级过滤器	Second Filter	1		
17	06990075	换挡杆球头	Shift lever ball	1		
18	12020004	摇臂橡胶防尘盖M10	Rubber dust cover of the rocker	8		
19	12020002	轮毂防尘盖(48)	Dust cover of the hub(48)	4		
20	07020102	消声器拉簧	Tension spring	2		
21	01990024	排气管垫	Gasket for the exhaust pipe	1		
22	07020007	刹车开关拉簧	Brake switch spring	1		
23	06020025	坐垫橡胶	Rubber for Seat	4		

电器、灯具、电缆 Electrical Components, Lights, Wire

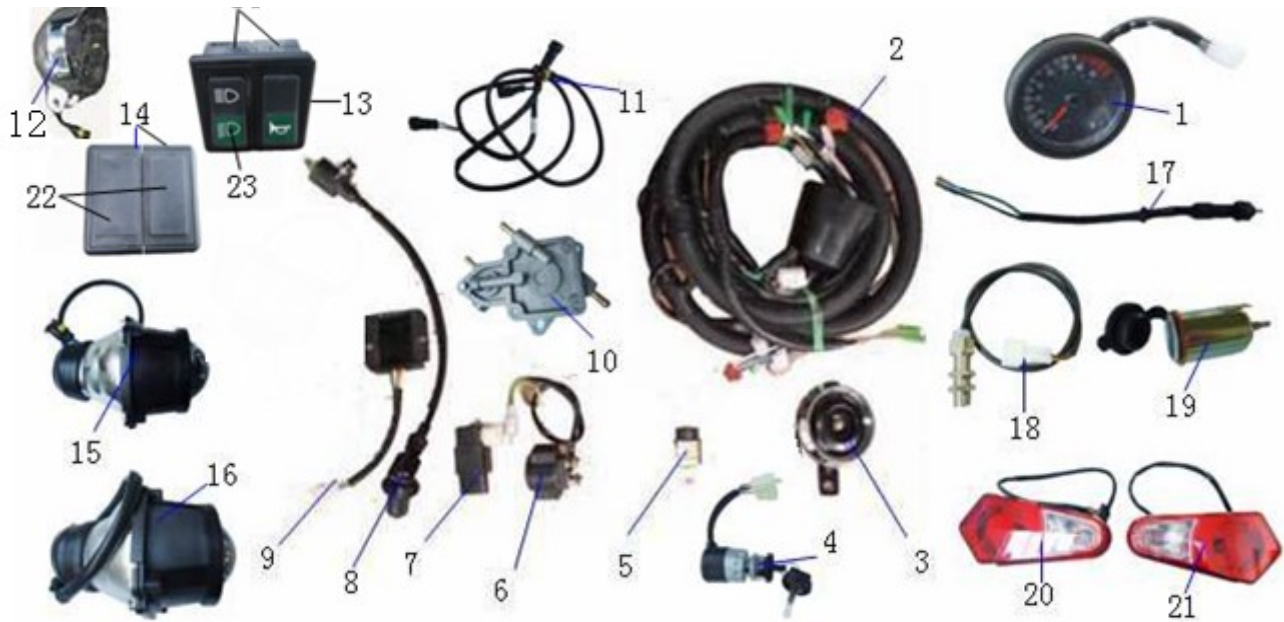

序	件号	中文名称	英文名称	数量	单价	
NO	Code name	Chinese	Description	Q'ty	¥	\$
1	10050037	仪表	Instrument	1		
2	08010047	电缆线	Main Cable	1		
3	10070001	普通喇叭DJ128/DJ70	Horn DJ128/DJ70	1		
4	10080018	电门锁	Lock	1		
5	01020041	CM6321继电器	CM6321 Relay	1		
6	01020021	继电器	Relay	1		
7	01020016	点火器	Igniter	1		
8	01020022	高压包	Ignition Coil	1		
9	01020017	整流器	Rectifier	1		
10	10060013	汽油泵	Fuel pump	1		
11	08010052	副电缆	Vice-cable	1		
12	09040004-XP	三星装饰灯	Fog Light	3		
13	10010081	喇叭开关	Horn Switch	1		
14	10010082	白板开关盒	Blank switch cover	4		
15	09010042	前大灯（近光）	Headlight (Lower beam)	1		
16	09010041	前大灯（远光）	Headlight (High beam)	1		
17	10010035	刹车开关（分插）	Brake switch	1		
18	10040026	车速传感器	Mileage sensor	1		
19	10990020	点烟器电源座	Cigar lighter	1		
20	09030034	后尾灯（左）	Rear light (Left)	1		
21	09030035	后尾灯（右）	Rear light (Right)	1		
22	10010083	白板开关盖	Blank switch cover	2		
23	10010080	大灯开关	Headlight Switch	1		

覆盖件 Body Covering

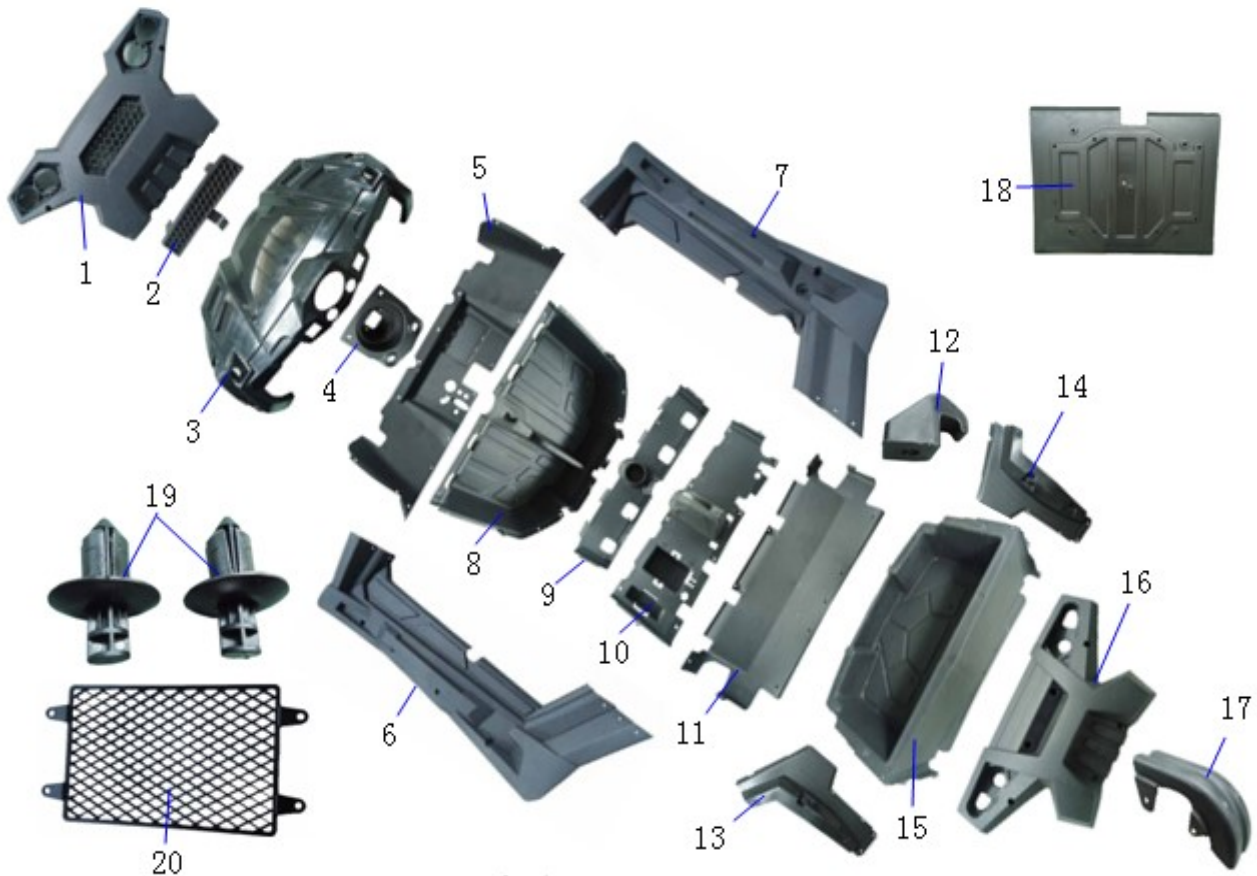

序	件号	中文名称	英文名称	数量	单价	
NO	Code name	Chinese	Description	Q'ty	¥	\$
1	03030424	前杠	Front guard	1		
2	03030423	小风窗格	Air inlet	1		
3	03010277	引擎盖	Engine cover	1		
4	03030418	仪表壳	Meter housing	1		
5	03030630	脚踏板上围	Upper round of footrest	1		
6	03030428	加长边条(左)	Left side(lengthen)	1		
7	03030429	加长边条(右)	Right side(lengthen)	1		
8	03030426	脚踏板	Footrest	1		
9	03030421	加长连接板	Connecting plate(lengthen)	1		
10	03030631	档位板	Gear plate	1		
11	03030632	背板	Backboard	1		
12	03030419	杂物箱挂钩	Hanger of luggage case	8		
13	03010275	后轮眉(左)	Rear car wheel trims L.	1		
14	03010276	后轮眉(右)	Rear car wheel trims R.	1		
15	03030427	后杂物箱	Rear luggage case	1		
16	03030634	后杠	Rear guard	1		
17	03030633	链罩后护板	Chain guard	1		
18	03030417	底板	Baseplate	1		
19	15010044	膨胀螺栓A(大)	Expansion anchor bolt	22		
20	03030422	G300网罩	G300 Net Cover	1		

电瓶/线束 Cabel, Cavans Mesh

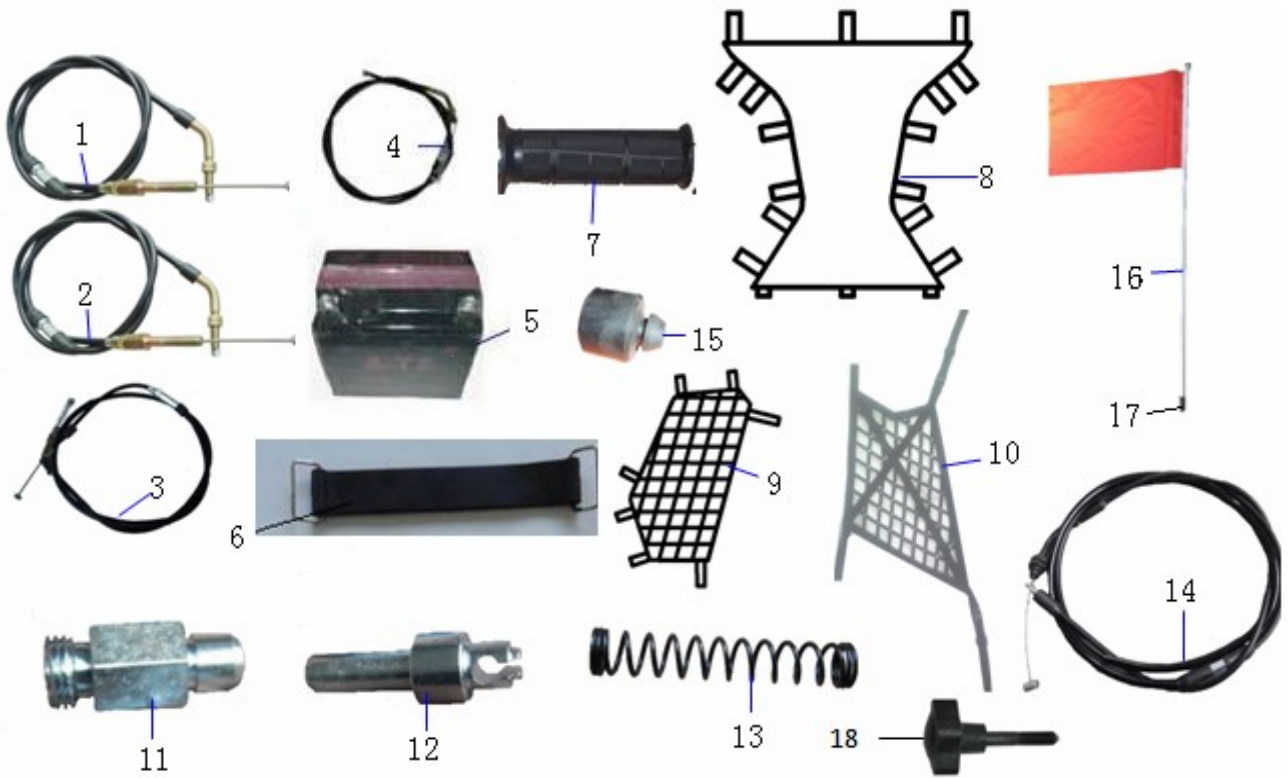

序	件号	中文名称	英文名称	数量	单价	
NO	Code name	Chinese	Description	Q'ty	¥	\$
1	08020139	换挡拉线	Shift cable	1		
2	08020140	倒档拉线	Reverse cable	1		
3	08020142	手刹线	Hand Brake Cable	1		
4	08020141	油门线	Throttle Cable	1		
5	10990019	电瓶 (YTX9-BS)	Battery (YTX9-BS)	1		
6	06990062	电瓶扎带	Battery strap	1		
7	10020009	左把套 (XL-39)	L. Handlebar grip (XL-39)	2		
8	03990044	顶棚帆布	Top Roof Canvas	1		
9	03990048/49	小左右装饰网布	Side Decorative mesh (Small)	1		
10	03990046/47	大左右装饰网布	Side Decorative mesh (Big)	1		
11	02010843	固定套 (限位拉线)	Fixing sleeve	1		
12	02010844	拉线推杆	Cable pushrod	1		
13	07020088	拉线扭簧	Cable spring	1		
14	08020169	限位拉线	Limiting cable	1		
15	06020094	电瓶橡胶垫	Battery rubber washer	3		
16	12990022	旗杆	Flag rod	1		
17	06020099	旗杆橡胶套	Flag rod rubber washer	1		
18	06990073	梅花形旋钮	Handle Bar	1		

轮胎、钢圈 Wheel and Tire



序	件 号	中文名称	英文名称	数量	单价	
NO	Code name	Chinese	Description	Q'ty	¥	\$
1	06010007	轮胎21*7-10	Tyre 21*7-10	2		
	06010056	“W”齿形轮胎21*7-10	“W”Tyre 21*7-10	2		
2	02040208	(腹板) 钢圈10*5.5	Iron Rim 10*5.5	2		
3	06010008	轮胎22*10-10	Tyre 22*10-10	2		
	06010057	“W” 齿形轮胎22*10-10	“W”Tyre 22*10-10	2		
4	02040209	(腹板) 钢圈10*8.0	Iron Rim 10*8.0	2		

碟刹总成 Disc Brake ASSY

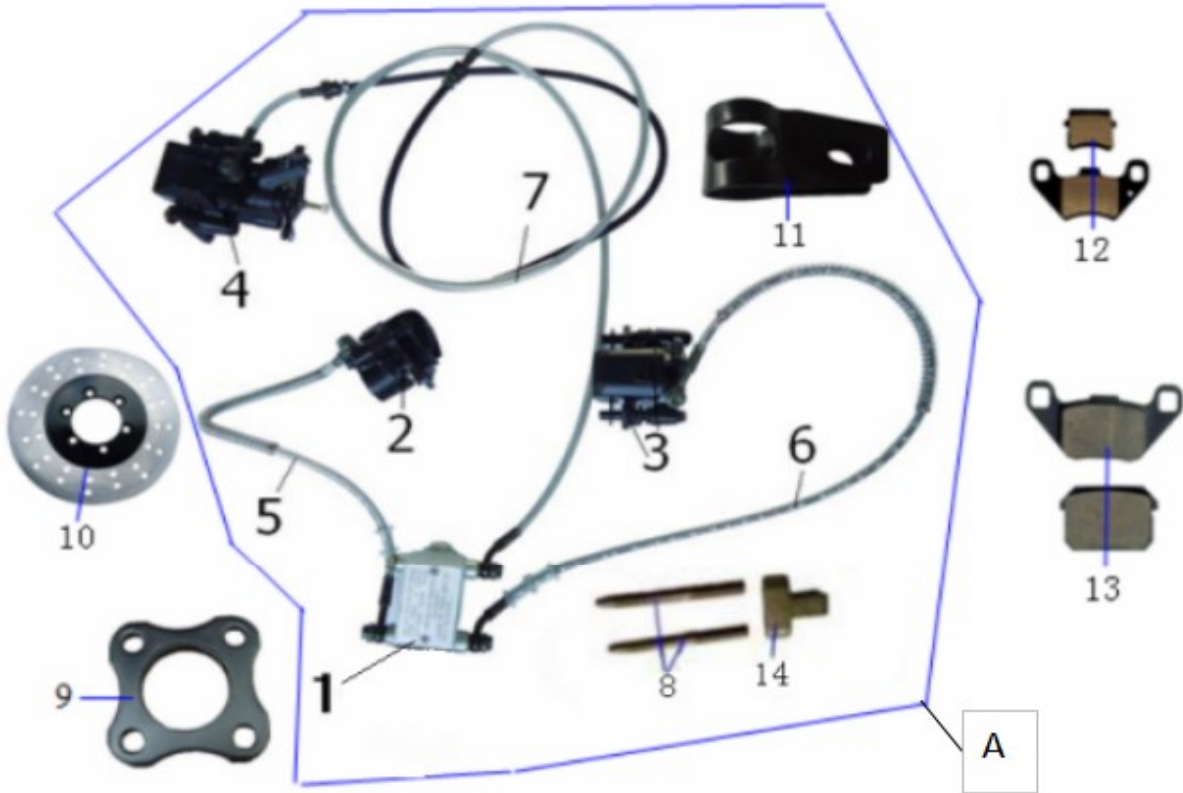

序	件号	中文名称	英文名称	数量	单价	
NO	Code name	Chinese	Description	Q'ty	¥	\$
A	04010077	碟刹总成	Disc Brake Assy	1		
1	190190-2	单油杯双顶杆总泵	Master Cylinder	1		
2	190018	圆弧AG左泵	Left Brake caliper	1		
3	190019	圆弧AG右泵	Right Brake caliper	1		
4	190020	05机械泵	Machnism Caliper	1		
5	190392	前右制动油管 760mm	Front Brake Line(R.)	1		
6	190391	前左制动油管 740mm	Front Brake Line(L.)	1		
7	190393	后制动油管 1550mm	Rear Brake Line	1		
8	190369-2	刹车顶杆L: 85mm	Brake Mandril	1		
	190369-3	刹车顶杆L: 90mm	Brake Mandril	1		
9	02010755	碟刹泵固定片	Fixed plate of brake pump	1		
10	04020011	(前) 碟刹盘128	Front Brake Disc 128mm	2		
11	12990004	碟刹管线夹	Thread Clip	6		
12	190009	F18A摩擦片	Brake Pad F18A	2付		
13	190010	F035摩擦片	Brake Pad F035	1付		
14	190196	顶杆固定座 (长)	Knock Pin Seating	1		

随车工具/灯泡 Tool Kit, Bulbs

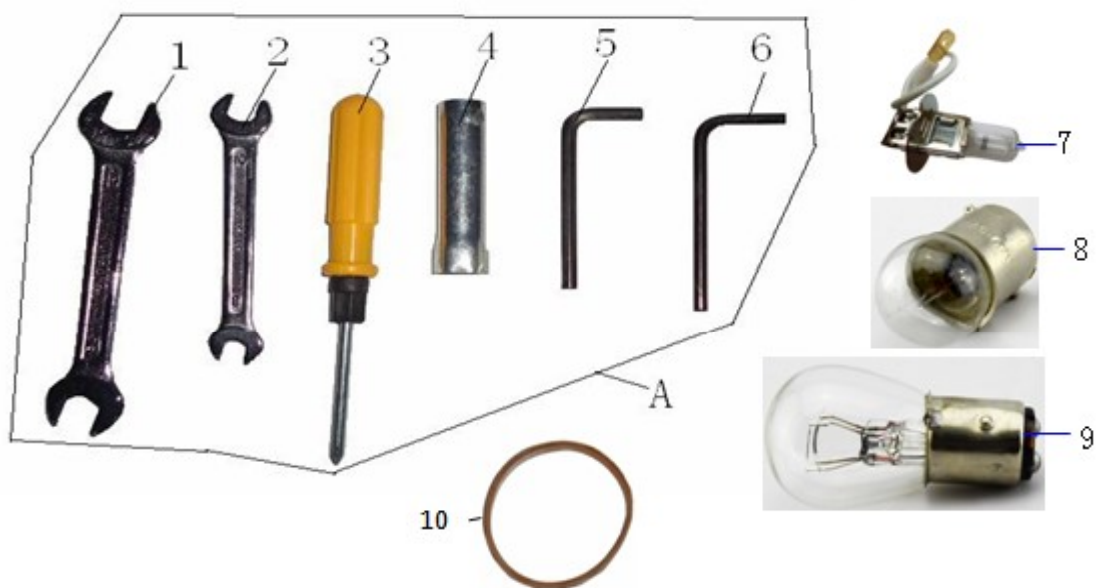

序 NO	件号 Code name	中文名称 Chinese	英文名称 Description	数量 Q'ty	单价 ¥ \$	
A		随车工具	Tools	1		
1	16010005	开口扳手12-14	Open Spanner(12-14)	1		
2	16010004	开口扳手8-10	Open Spanner(8-10)	1		
3	16010006	双头螺丝刀	Dual-Purpose Screwdriver	1		
4	16010007	火花塞套筒S=16	Spark Plug Box Spanner(S=16)	1		
5	16010002	内六角扳手6mm	Socket Head Screw Wrench(6mm)	1		
6	16010001	内六角扳手5mm	Socket Head Screw Wrench(5mm)	1		
7		H3 12V35W灯泡	H3 12V35W Bulbs	4		
8	00608013	转向灯灯泡(无色)	Turn light bulb	4		
9	00608009	刹车灯无色灯泡	Brake light bulb	2		
10	12040013	橡皮筋	rubber	1		

DF200GKV零件目录图册

DF200GKV PARTSLIST



FOREWORD

When you are going to order parts you may take this booklet as reference but any differences please take the reality on vehicle as standard.

To find out the name, Item code or fitment you may check in the illustration with the size and appearance .Then with the no. in the illustration you will find out the name, item code and quantity.

There will no notice to you ahead of any change of the information in this booklet.

