

# DF200GHD零件目录图册

## DF200GHD PARTSLIST



### **FOREWORD**

When you are going to order parts you may take this booklet as reference but any differences please take the reality on vehicle as standard.

To find out the name, Item code or fitment you may check in the illustration with the size and appearance .Then with the no. in the illustration you will find out the name, item code and quantity.

There will no notice to you ahead of any change of the information in this booklet.

## 发动机 Engine

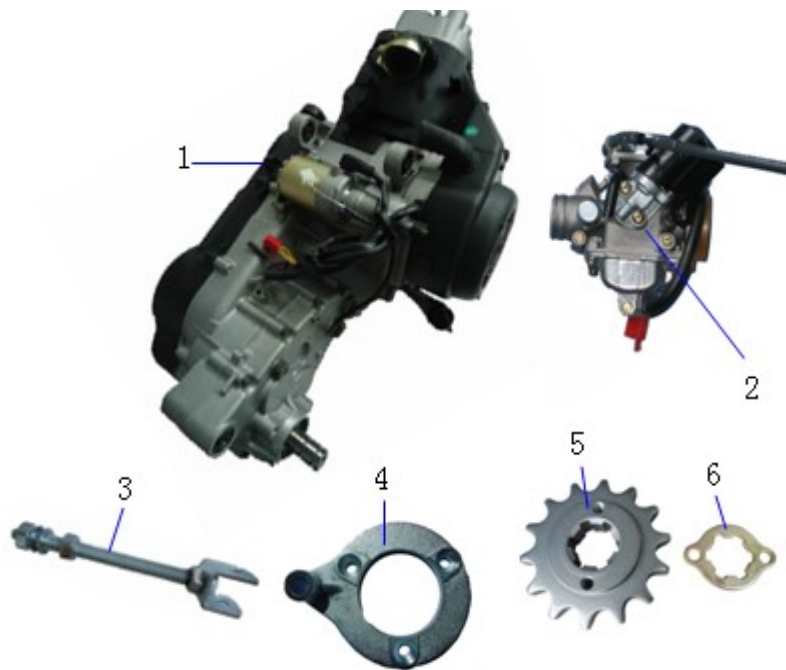

序 NO.	件 号 Code name	中文名称 Chinese	英文名称 Description	数量 Q'ty	单价	
					¥	\$
1	01010002	发动机(11级直流)	Engine	1		
2	01030012	化油器(美标非上路)	Carburator	1		
3	02010819	调节拉杆	Control Rod	1		
4	02010746	调节固定板	Adjust Dead Pate	1		
5	02040112	牙盘(F150主动链轮)	F150 Drive Sprocket	1		
6	02010828	F150主动链轮锁片	F150 Locking Plate	1		

## 曲轴箱总成(一) Crankcase Assy

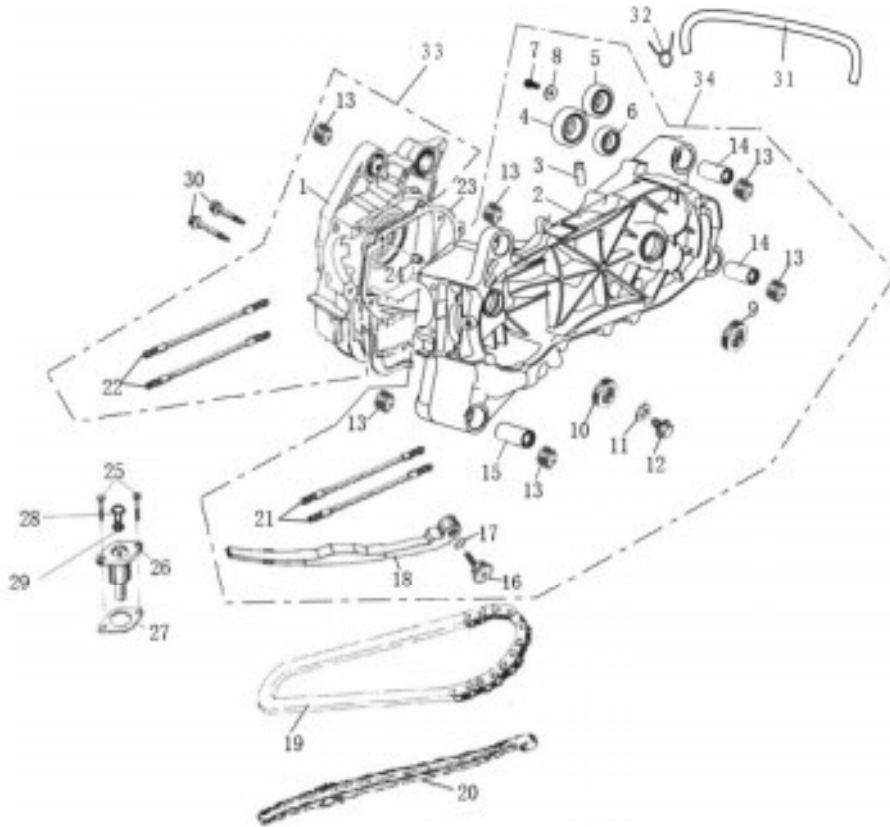

序 NO.	件 号 Code name	中文名称 Chinese	英文名称 Description	数量 Q'ty	单价	
					¥	\$
1	2. 20. 05. 09. 02000	右箱体	R.Crankcase Assembly	1		
2	2. 20. 04. 66. 07000	左箱体本体总成	L.Crankcase Assembly	1		
3	1. 20. 07. 32. 12000	通气管接头	Breather Pipe Joint	1		
4	1. 00. 01. 6204	轴承6204	Bearing 6204	1		
5	1. 00. 01. 6203	轴承6203	Bearing 6203	1		
6	1. 00. 01. 6202	轴承6202	Bearing 6202	1		
7	1. 05. 01. 09. 0612	螺栓M6×12	Bolt M6×12	1		
8	1. 20. 20. 20. 17000	大垫圈6	Washer 6	1		
9	1. 20. 20. 01. 08000	输入轴油封20×32×6	Oil-Seal 20×32×6	1		
10	1. 20. 04. 01. 13000	曲轴油封19.8×30×5	Oil-Seal 19.8×30×5	1		
11	1. 20. 04. 01. 03000	平垫 12×18×1	Gasket 12×18×1	1		
12	1. 20. 04. 01. 14000	放油螺栓M12×1.5×	Bolt M12×1.5×14	1		
13	1. 20. 04. 01. 09000	前减震套	Front Shock Absorber Sheath	5		
14	1. 20. 04. 65. 15000	衬套42	Bush 42	2		

15	1. 20. 04. 65. 16000	衬套50	Bush 50	1		
16	1. 20. 13. 01. 01000	固定拉力杆螺钉	Screw	1		
17	1. 20. 13. 01. 02000	O形圈16×1.5	O-Ring 16×1.5	1		
18	1. 20. 13. 01. 05000	拉力杆	Tension Rod	1		
19	1. 20. 13. 32. 04000	正时链条	Timing Chain	1		

### 曲轴箱总成 (二) Crankcase Assy

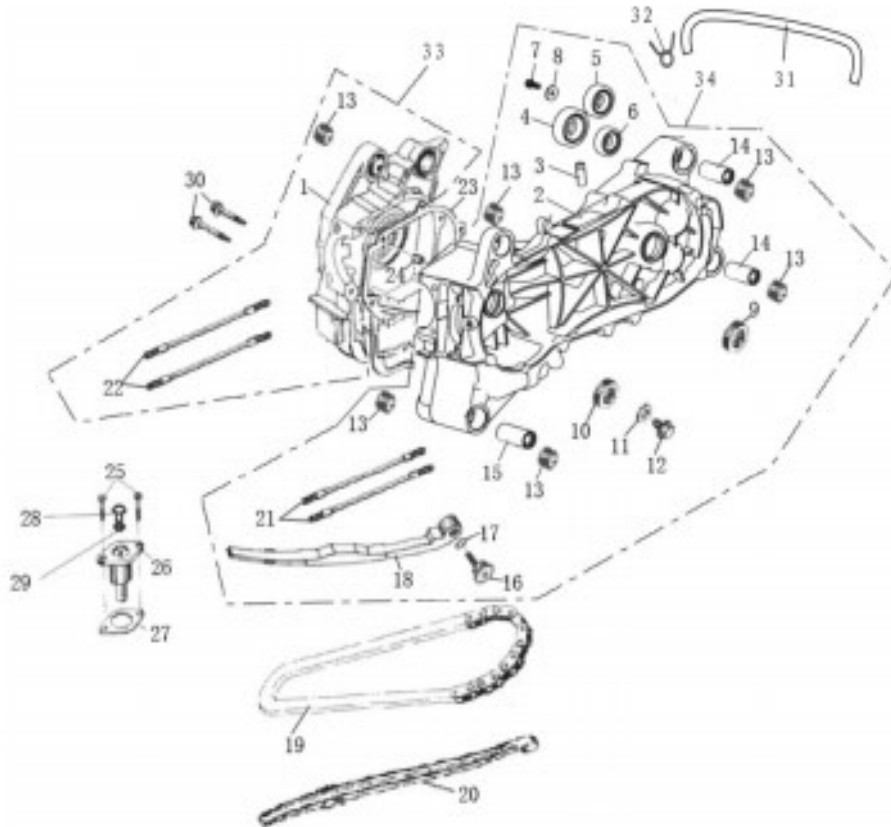

序	件号	中文名称	英文名称	数量	单价	
NO.	Code name	Chinese	Description	Q'ty	¥	\$
20	1. 20. 13. 01. 06000	分气链条导件	Chain Guide	1		
21	1. 20. 04. 06. 04000	双头螺柱M8×209	Stud bolt M8×209	2		
22	1. 20. 05. 06. 01000	双头螺柱M8×201	Stud bolt M8×201	2		
23	1. 20. 04. 01. 05000	右箱体垫	Gasket	1		
24	1. 20. 04. 01. 01000	定位套ø8×14	Locating Bush ø8×14	2		
25	1. 05. 01. 09. 0622	螺栓M6×22	Bolt M6×22	2		
26	1. 20. 13. 01. 07000	压链器	Chain Adjuster	1		
27	1. 20. 13. 01. 03000	(压链器) 纸垫	Gasket	1		
28	1. 20. 13. 01. 08000	扁头螺钉	Screw	1		
29	1. 20. 13. 01. 09000	O形圈9.5×1.5	O-Ring 9.5×1.5	1		
30	1. 05. 01. 09. 0650	螺栓M6×50	Bolt M6×50	2		
31	1. 20. 04. 65. 12000	变速箱通风管	Gearcase Breather Pipe	1		
32	1. 20. 04. 65. 17000	卡箍11.5	Clamp 11.5	1		

33	2. 20. 05. 67. 99000	右箱体总成	R.Crankcase Assembly	1		
34	2. 20. 04. 66. 99000	左箱体总成	L.Crankcase Assembly	1		

### 变速箱盖总成(一) Gearcase Assy

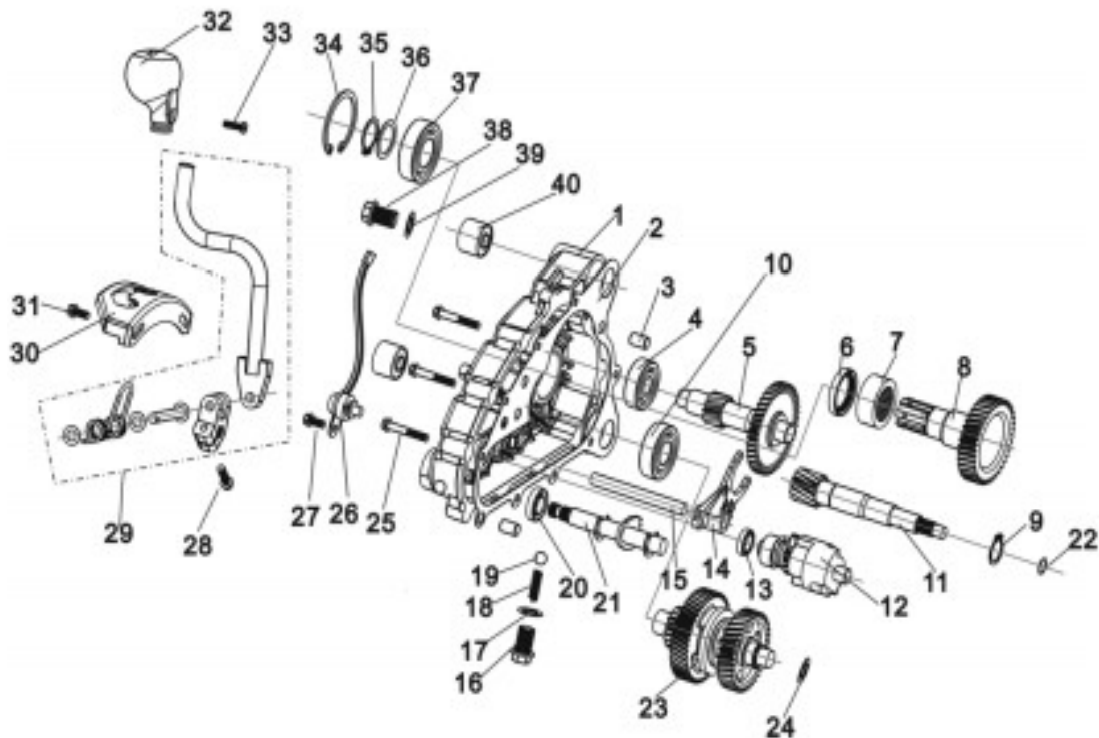

序	件号	中文名称	英文名称	数量	单价	
NO.	Code name	Chinese	Description	Q'ty	¥	\$
1	2. 20. 20. 65. 01000	变速箱盖	Gearcase cover	1		
2	1. 20. 20. 65. 08000	变速箱盖垫片	Gearcase Gasket	1		
3	1. 20. 01. 01. 01000	定位套	Locating Bush	2		
4	1. 00. 01. 6302	轴承6302	Bearing 6302	1		
5	1. 20. 20. 65. 10000	倒档齿轮轴组	Reverse Gear Shaft Assy	1		
6	1. 20. 20. 65. 14000	输出轴油封	Oil Seal of Output Shaft	1		
7	1. 00. 01. 4905	滚针轴承RNA4905	Needle Bearing RNA4905	1		
8	1. 20. 20. 65. 03000	输出轴	Output Shaft	1		
9	1. 05. 06. 02. 2000	轴用挡圈20	Check Ring 20	1		
10	1. 00. 01. 6204	轴承6204	Bearing 6204	2		

11	1.20.20.65.02000	变速箱输入轴	Input Shaft	1		
12	1.20.20.65.18000	变档鼓组件	Shift Drum Assy	1		
13	1.20.20.65.19000	变档鼓油封	Oil Seal	1		
14	1.20.20.65.11000	拨叉	Shift Fork	1		
15	1.20.20.65.21000	拨叉轴	Shift Rail	1		
16	1.20.04.65.18000	空心螺栓	Hollow Bolt	1		
17	1.20.04.65.19000	垫圈14×22×1	Washer 14×22×1	1		
18	1.20.04.65.20000	限位弹簧	Limit Spring	1		
19	1.20.04.65.21000	钢球13/32	Steel Ball	1		

### 变速箱盖总成 (二) Gearbox Cover Assy

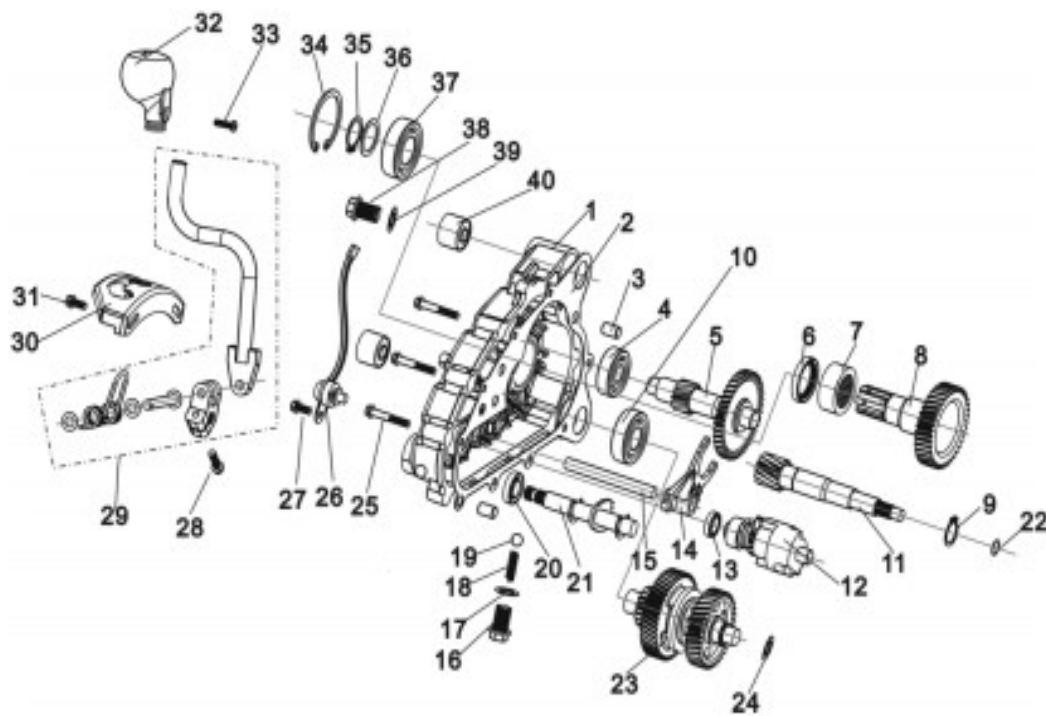

序	件号	中文名称	英文名称	数量	单价	
NO.	Code name	Chinese	Description	Q'ty	¥	\$
20	1.20.20.65.16000	换档轴油封	Oil Seal of Shift Shaft	1		
21	1.20.20.65.17000	换档轴组件	Shift Shaft Assy	1		
22	1.20.20.65.20000	O形圈10×2.5	O-Ring 10×2.5	1		
23	1.20.20.65.09000	中间齿轮轴组	Intermediate Gear Shaft	1		
24	1.20.04.65.23000	垫圈15×19×1	Washer 15×19×1	1		
25	1.05.01.09.0640	螺栓M6×40	Bolt M6×40	10		
26	1.20.32.65.08000	档位传感器组件	Gear Sensor Module	1		

27	1.05.01.09.0612	螺栓M6×12	Bolt M6×12	1		
28	1.05.01.08.0622	螺栓M6×22	Bolt M6×22	1		
29						
30						
31						
32						
33						
34	1.05.06.01.5200	孔用挡圈52	Check Ring 52	1		
35	1.05.06.02.2500	轴用挡圈25	Check Ring 25	1		
36	1.20.04.65.22000	垫圈25×33×1	Washer 25×33×1	1		
37	1.00.01.6205-2RS	轴承6205-2RS	Bearing 6205-2RS	1		
38	1.20.04.01.14000	放油螺栓M12×1.5×	Bolt M12×1.5×14	1		
39	1.20.04.01.03000	平垫 12×18×1	Gasket 12×18×1	1		
40	1.20.04.01.09000	前减震套	Front Shock Absorber	2		

### 左盖总成 Left Cover Assy

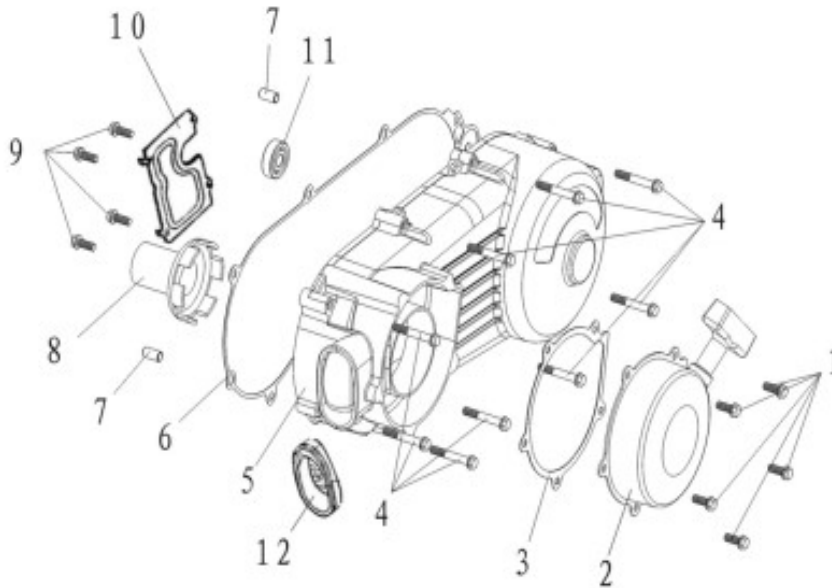

序	件号	中文名称	英文名称	数量	单价	
NO.	Code name	Chinese	Description	Q'ty	¥	\$
1						
2						
3						
4	1.05.01.09.0640	螺栓M6×40	Bolt M6×40	8		
5	2.20.06.65.01001	左盖	Left Cover	1		
6	1.20.06.01.07000	左盖垫	Left Cover Gasket	1		

7	1. 20. 04. 01. 01000	定位套 $\phi 8 \times 14$	Locating Bush $\phi 8 \times 14$	2		
8						
9	1.05.02.03.4208	自攻螺钉ST4.2×8	Tapping Screw ST4.2×8	4		
10	1. 20. 06. 01. 03000	通气导板	Breather Guide Plate	1		
11	1. 00. 01. 6200-2RS	轴承6200-2RS	Bearing 6200-2RS	1		
12	1. 20. 06. 01. 10001	吸风口罩	Cover of Exhaust Opening	1		

**右箱体端盖总成 Right Cover Assy**

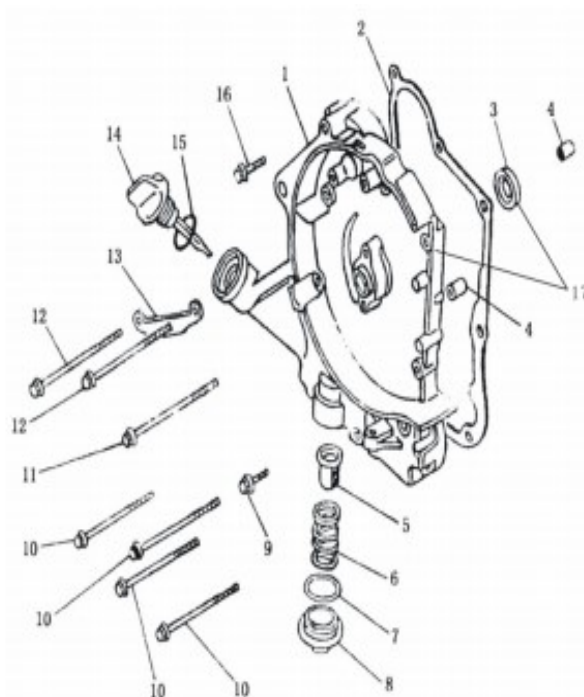

序	件 号	中文名称	英文名称	数量	单价	
NO.	Code name	Chinese	Description	Q'ty	¥	\$
1	2. 20. 07. 01. 01000	右盖	Right Cover	1		
2	1. 20. 07. 01. 06000	右盖垫	Right Cover Gasket	1		
3	1. 20. 04. 01. 13000	曲轴油封19.8×30×5	Oil Seal 19.8×30×5	1		



4	1.20.04.01.01000	定位套 φ8×14	Locating Bush φ8×14	2		
5	1.20.07.01.09000	滤油网	Oil-Filter Screen	1		
6	1.20.07.01.03000	滤油网弹簧	Oil-Filter Screen Spring	1		
7	1.20.07.01.04000	O形圈30.5×3	O-Ring 30.5×3	1		
8	1.20.07.01.02000	滤油网螺帽	Oil-Filter Screen Nut	1		
9	1.05.01.09.0632	螺栓M6×32	Bolt M6×32	1		
10	1.05.01.09.0695	螺栓M6×95	Bolt M6×95	4		
11	1.05.01.09.06100	螺栓M6×100	Bolt M6×100	1		
12	1.05.01.09.06110	螺栓M6×110	Bolt M6×110	2		
13	1.20.07.01.08000	触发线卡	Trigger Line Card	1		
14	1.20.07.01.05000	机油尺	Oil Level Gauge	1		
15	1.20.07.01.07000	O形圈18×3	O-Ring 18×3	1		
16	1.05.01.09.0635	螺栓M6×35	Bolt	1		
17	2.20.07.01.99000	右盖总成	Right Cover Assy	1		

### 气缸体总成 Cylinder Body Assy

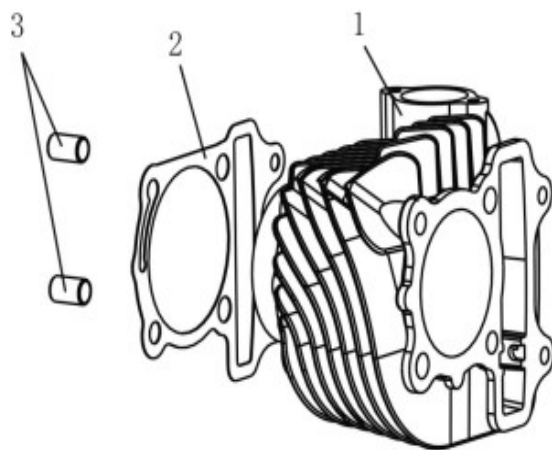

序	件号	中文名称	英文名称	数量	单价	
NO.	Code name	Chinese	Description	Q'ty	¥	\$
1	1.20.02.09.03000	气缸体	Cylinder Block	1		

2	1.20.02.09.01000	气缸垫	Cylinder Block Gasket	1		
3	1.20.01.01.01000	定位套 φ10×16	Locating Bush φ10×16	2		

### 气缸头总成 Cylinder Head Assy

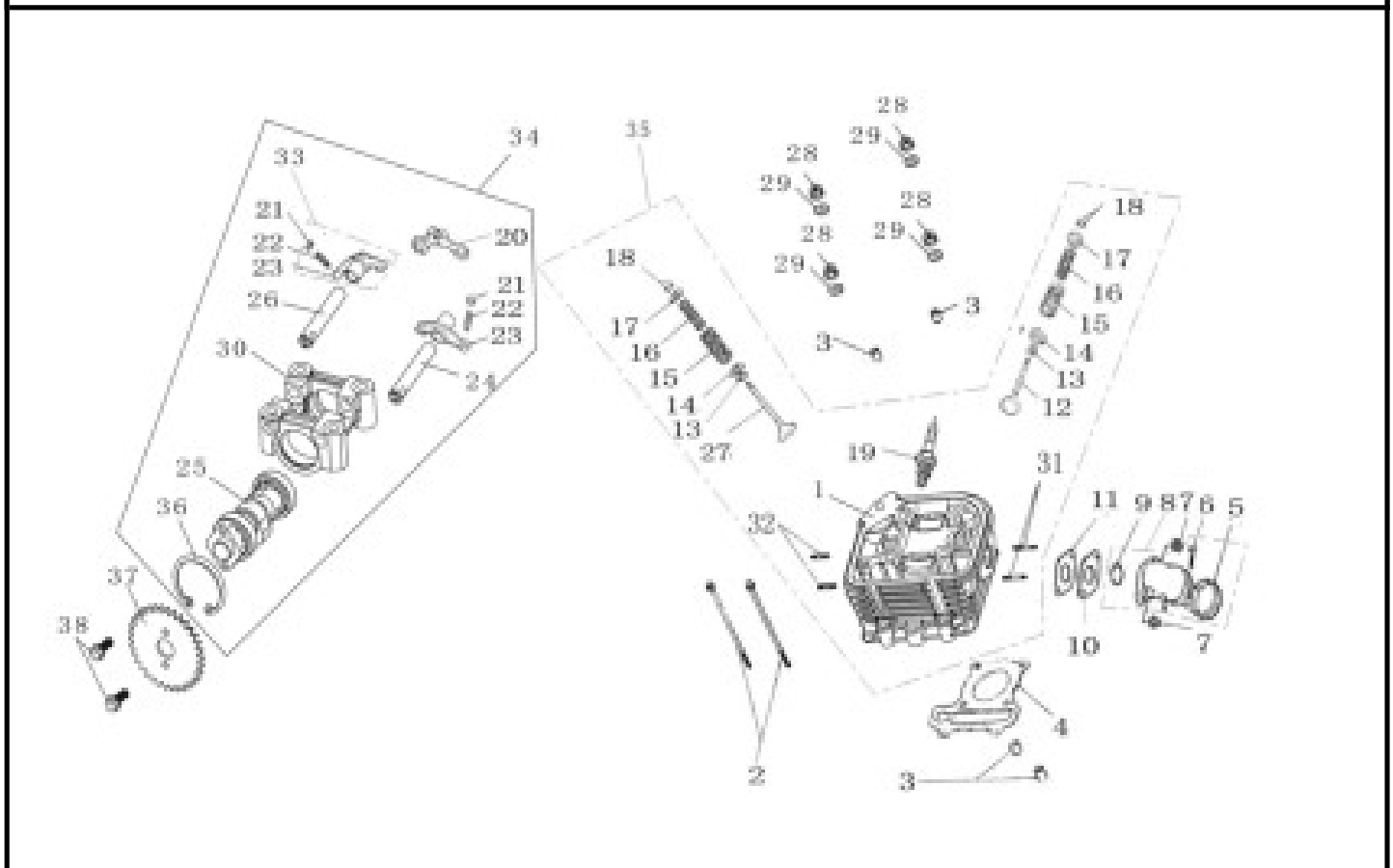

序	件号	中文名称	英文名称	数量	单价	
NO.	Code name	Chinese	Description	Q'ty	¥	\$
1	2.20.01.09.13000	气缸头组本体(无补气)	Cylinder Head	1		

2	1.05.01.09.06100	螺栓M6×100	Bolt M6×100	2	
3	1.20.01.01.01000	定位套 φ10×16	Locating Bush φ10×16	4	
4	1.20.01.09.15000	气缸头垫片	Cylinder Head Gasket	1	
5	1.20.01.01.16010	进气管夹	Pipe Clamp	1	
6	1.05.02.01.0425	螺钉M4×25	Screw M4×25	1	
7	1.05.04.02.0600	螺母M6	Nut M6	2	
8	1.20.01.01.16000	进气管总成	Intake-Tube Assy	1	
9	1.00.14.265180	O形圈26.5×1.8	O-Ring 26.5×1.8	1	
10	1.20.01.01.12000	化油器隔热板	Thermal Baffle	1	
11	1.20.01.01.11000	隔热板纸垫板	Base Plate	1	
12	1.20.01.06.06000	进气门	Inlet Valve	1	
13	1.20.01.01.14000	气门油封	Valve Oil Seal	2	
14	1.20.01.01.10000	(气门弹簧) 垫片	Gasket	2	
15	1.20.01.06.09000	气门外弹簧	Outer Valve Spring	2	
16	1.20.01.06.08000	气门内弹簧	Inner Valve Spring	2	
17	1.20.01.01.05000	气门弹簧座	Valve Spring Retainer	2	
18	1.20.01.01.07000	气门锁块	Valve Cotter	4	
19	1.20.01.01.17000	火花塞	Spark Plug	1	
20	1.20.12.01.05000	止动板组	Stop Plate	1	
21	1.20.12.01.04020	调整螺母	Adjusting Nut	2	
22	1.20.12.01.04030	调整螺丝	Adjusting Screw	2	
23	1.20.12.06.04010	(气门) 摇臂	Rocker Arm	2	

### 气缸头总成 (二) Cylinder Head Assy

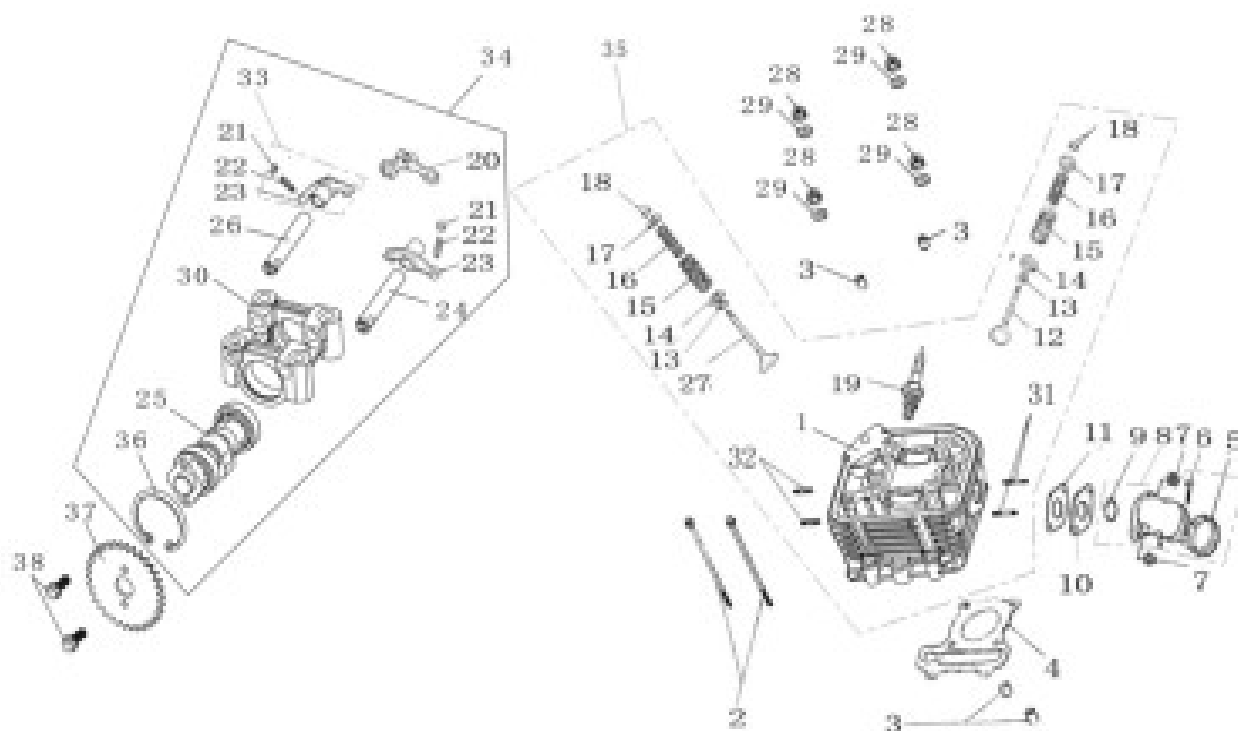

序	件号	中文名称	英文名称	数量	单价	
NO.	Code name	Chinese	Description	Q'ty	¥	\$
24	1.20.12.06.03000	进气摇臂轴组	Inlet Rocker Arm Shaft Assy	1		
25	1.20.11.06.01000	凸轮轴总成	Camshaft Assy	1		
26	1.20.12.06.02000	排气摇臂轴	Inlet Rocker Arm Shaft	1		
27	1.20.01.06.04000	排气门	Exhaust Valve	1		
28	1.05.04.02.0800	螺母M8	Nut M8	4		
29	1.20.04.01.06000	垫圈8	Washer 8	4		
30	2.20.12.06.01000	凸轮轴座	Camshaft Retainer	1		
31	1.20.01.01.03000	双头螺柱M6×63	Stud Bolt M6×63	2		
32	1.20.01.08.02000	双头螺柱M8×32	Stud Bolt M8×32	2		
33	1.20.12.06.04000	气门摇臂	Valve Rocker	2		
34	2.20.12.06.99000	凸轮轴座总成	Camshaft Retainer Assy	1		
35	2.20.01.67.99000	气缸头总成	Cylinder Head Assy	1		
36	1.05.06.01.3500	孔用挡圈35	Check Ring	1		
37	1.20.11.32.02000	正时链轮	Timing Sprocket	1		
38	1.05.01.08.0512	螺栓M5×12	Bolt M5×12	2		

气缸头盖总成 Cylinder Head Cover Assy

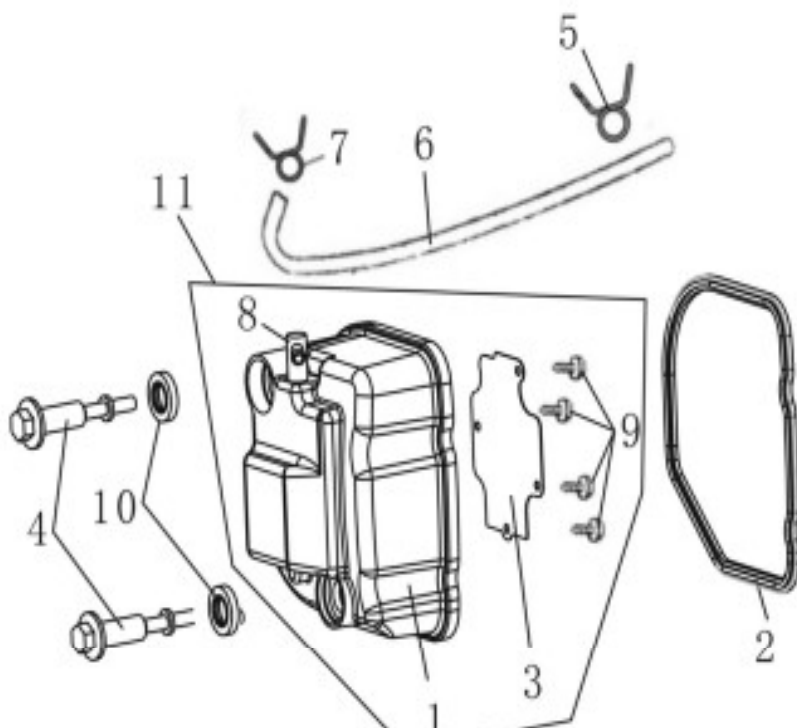

序	件号	中文名称	英文名称	数量	单价	
NO.	Code name	Chinese	Description	Q'ty	¥	\$
1	2.20.03.06.01000	气缸头盖	Cylinder Head Cover	1		
2	1.20.03.06.03000	气缸盖密封圈	Seal Ring of Cylinder Head Cover	1		
3	1.20.03.01.02008	盖片	Cover Slip	1		
4	1.20.03.32.30000	盖罩螺栓	Bolt	2		
5	1.20.03.01.05010	管夹	Pipe Clamp	1		
6	1.20.03.01.05000	通气管组	Breather Pipe Assy	1		
7	1.20.03.01.05020	管夹	Pipe Clamp	1		
8	1.20.03.01.04000	管接头组件	Pipe Joint Assy	1		
9	1.05.02.03.4208	自攻螺钉ST4.2×8	Tapping Screw ST4.2×8	4		
10	1.20.03.32.31000	衬胶垫圈	Rubber Gasket	2		
11	2.20.03.06.99000	气缸头盖总成	Cylinder Head Cover Assy	1		

曲轴连杆组件、活塞组件 Connecting Rod of Crank-shaft Assy

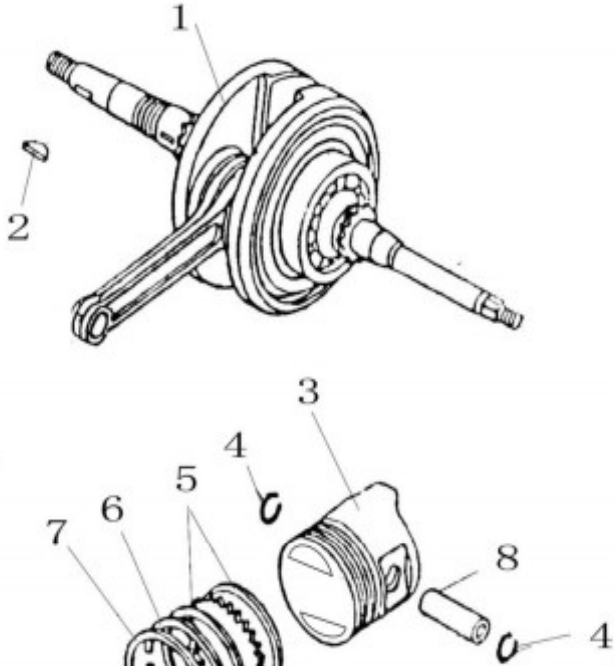



序	件号	中文名称	英文名称	数量	单价	
NO.	Code name	Chinese	Description	Q'ty	¥	\$
1	1.20.09.65.01000	曲轴连杆组	Connecting Rod of Crank-shaft	1		
2	1.20.09.01.01010	半圆键	Woodruff Key	1		
3	1.20.10.08.01000	活塞	Piston	1		
4	1.20.10.01.04000	活塞销卡簧	Clamp Spring	2		
5	1.20.10.08.02000	油环组合(含刮片环)	Oil Ring	1		
6		第二道气环	Piston Ring 1			
7		第一道气环	Piston Ring 2			
8	1.20.10.08.03000	活塞销	Piston Pin	1		

**起动电机总成 Starting Motor Assy**

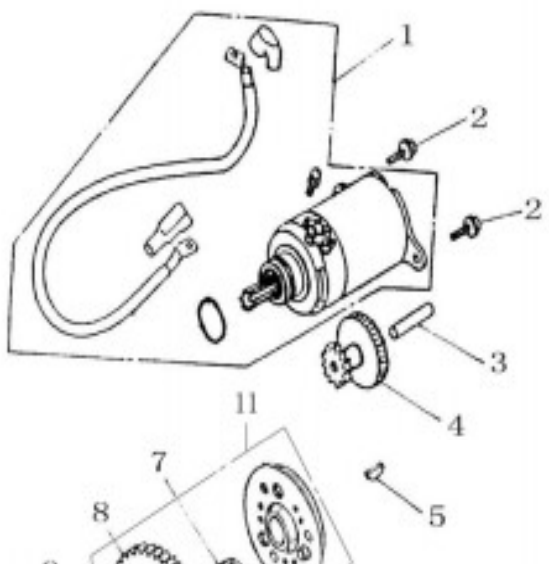

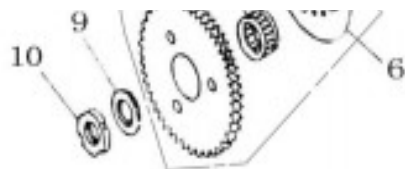

序 NO.	件号 Code name	中文名称 Chinese	英文名称 Description	数量 Q'ty	单价	
					¥	\$
1	1.20.18.01.01000	起动电机总成	Starter Motor Assy	1		
2	1.05.01.09.0616	螺栓M6×16	Bolt M6×16	2		
3	1.20.18.01.02000	齿轮轴	Gear Shaft	1		
4	1.20.18.01.03000	过渡齿轮	Transition Gear	1		
5	1.20.09.01.01010	半圆键	Woodruff Key	1		
6	1.20.19.08.01020	超越离合器组件	Overrunning Coupler Assy	1		
7	1.20.19.01.01040	滚针轴承	Needle Bearing	1		
8	1.20.19.03.01030	从动齿轮组合	Driven Gear Assy	1		
9	1.20.19.01.03000	垫片	Gasket	1		
10	1.20.19.01.02000	锁紧螺母SM22×1左	Locknut SM22×1 (L.)	1		
11	1.20.19.08.01000	起动超越离合器	Overrunning Coupler	1		

主、从动皮带轮总成 Driving and Driven Pulley Assy

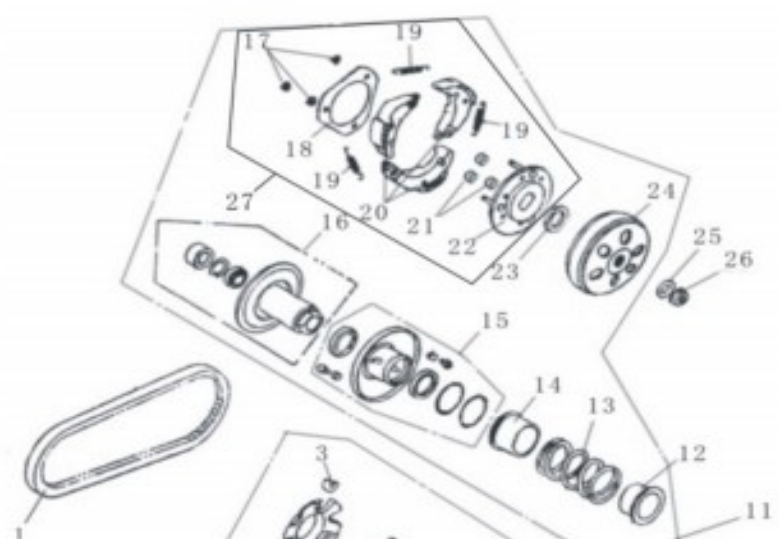

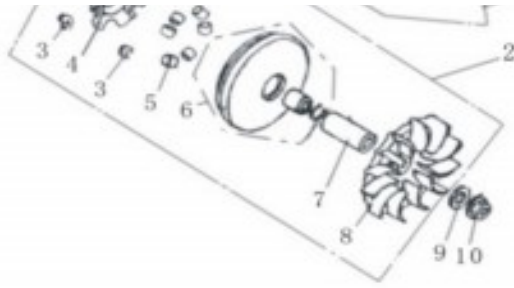

序 NO.	件号 Code name	中文名称 Chinese	英文名称 Description	数量 Q'ty	单价 ¥ \$	
1	152019000	齿形三角皮带743-20-30	Tooth Belt	1		
2	1.20.21.01.01000	主动皮带轮总成	Driving Pulley Assy	1		
3	1.20.21.01.01060	琅块	Piece	3		
4	1.20.21.01.01050	拖动法兰	Drag Flange	1		
5	1.20.21.01.01040	离心滚柱	Right Capstan Assy	6		
6	1.20.21.01.01030	右主动轮组合	Right Capstan Assy	1		
7	1.20.21.01.01020	衬套	Bush	1		
8	1.20.21.01.01010	驱动皮带扇叶盘	Driving Belt Fan	1		
9	1.20.17.65.03001	垫圈12.5×25×7	Washer 12.5×25×7	1		
10	1.05.04.10.1213	螺母M12×1.25 H=10	Nut M12×1.25 H=10	1		
11	1.20.22.01.01000	从动皮带轮总成	Follower Pulley Assy	1		
25	1.05.05.04.1200	垫圈12.3×29×2.5	Washer 12.3×29×2.5	1		
26	1.05.04.10.1212	螺母M12×1.25 H=8	Nut M12×1.25 H=8	1		

磁电机部件、机油泵部件 Magneto and Oil pump

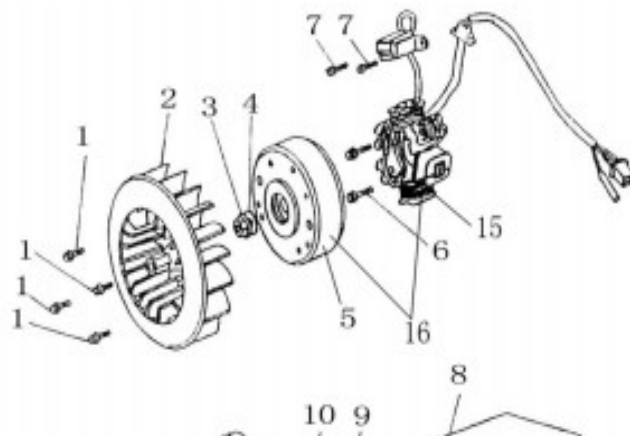



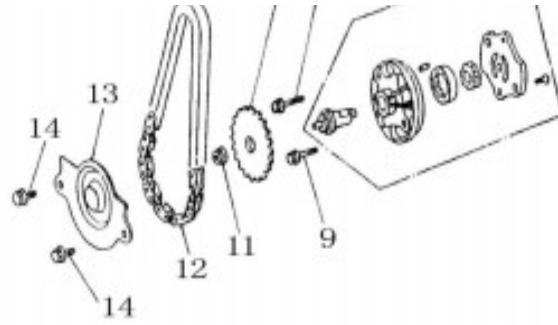

序	件号	中文名称	英文名称	数量	单价	
NO.	Code name	Chinese	Description	Q'ty	¥	\$
1	1.05.01.09.0618	六角法兰面螺栓M6×	Hexagon Bolt M6×18	4		
2	1.20.24.01.06000	风扇组合	Fan Assy	1		
3	1.05.04.10.1213	螺母M12×1.25 H=10	Nut M6 M12×1.25 H=10	1		
4	1.05.05.04.1201	平垫12-14HV	Flat Gasket 12-14HV	1		
5	1.20.16.01.01022	飞轮（直流11级）	Rotor Assy (DC 11)	1		
6	1.05.01.09.0620	六角法兰面螺栓M6×	Hexagon Bolt M6×20	2		
7	1.05.01.08.0512	六角螺栓M5×12	Hexagon Bolt M5×12	2		
8	1.20.14.01.03000	机油泵组合	Oil Pump Assy	1		
9	1.05.01.09.0625	螺栓M6×25	Bolt M6×25	2		
10	1.20.14.01.01000	油泵链轮	Oil Pump Sprocket Wheel	1		
11	1.05.04.02.0600	螺母M6	Nut M6	1		
12	1.20.14.01.04000	油泵链条	Oil Pump Chain	1		
13	1.20.14.01.02000	链轮端盖	Sprocket Wheel End Cap	1		
14	1.05.01.09.0612	螺栓M6×12	Bolt M6×12	2		
15	1.20.16.01.01012	定子组件（直流11级）	Stator Assy (DC 11)	1		
16	1.20.16.01.01002	磁电机总成（直流11	Magnetor Assy (DC 11)	1		

导风罩 Fan Cover Assy

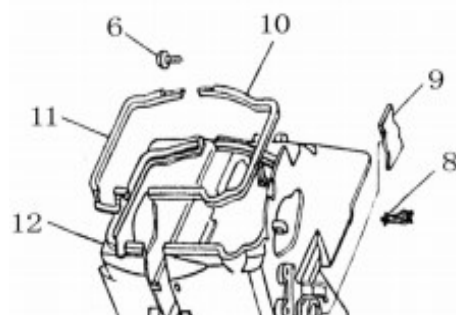

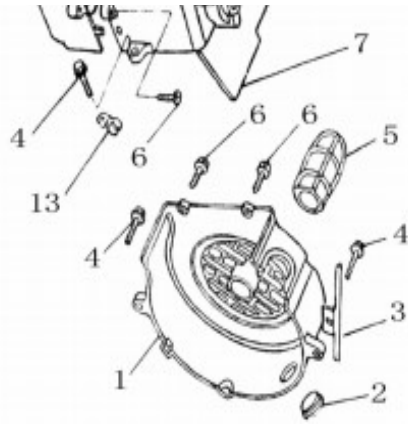

序	件号	中文名称	英文名称	数量	单价	
NO.	Code name	Chinese	Description	Q'ty	¥	\$
1	1.20.24.03.03000	风扇盖	Fan cover	1		
2	1.20.24.01.03020	窗口堵盖	Blanking Cap	1		
3	1.20.24.01.04000	电缆线夹	Cable Clamp	1		
4	1.05.01.09.0625	螺栓M6×25	Bolt M6×25	3		
5	1.20.24.01.03010	冷却导管	Cooling Duct	1		
6	1.05.02.15.4816	自攻螺钉ST4.8×16-F-	Tapping Screw ST4.8×16-F-H	5		
7	1.20.24.06.01020	161-B2上导风罩组件	Upper Fan Cover Assy	1		
8	1.20.24.01.01040	高压线夹	Cable Clamp	1		
9	1.20.24.01.01030	橡胶盖	Rubber Cover	1		
10	1.20.24.01.01010	161-B2上密封胶垫	Upper Rubber Mat	1		
11	1.20.24.01.02020	161-B2下密封胶垫	Lower Rubber Mat	1		
12	1.20.24.06.02000	161-B2下导风罩组合	Lower Fan Cover Assy	1		
13	1.20.24.01.05000	溢流管夹	Tubing Clamp	1		

**车架及配件 Frame and Accessories**



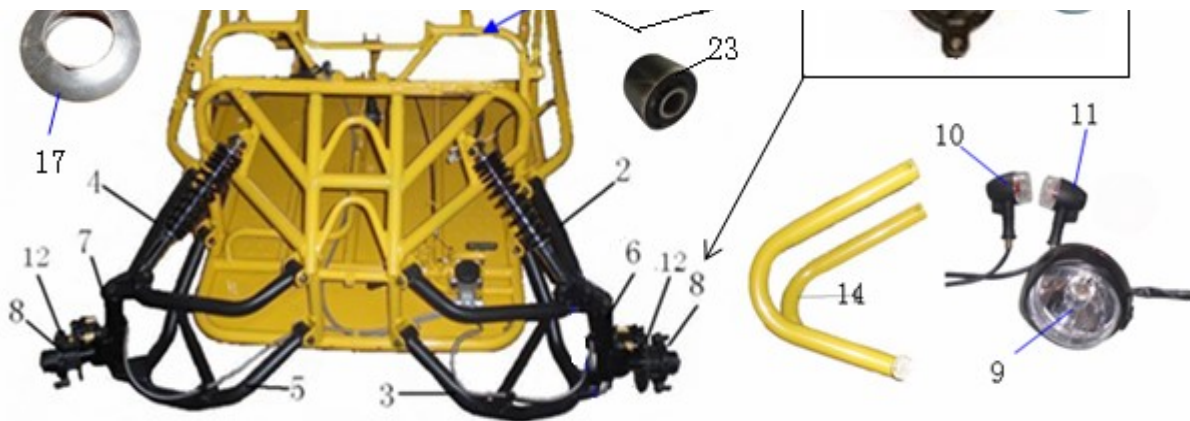

序	件号	中文名称	英文名称	数量	单价	
NO.	Code name	Chinese	Description	Q'ty	¥	\$
1	0201-200GKE	车架	Frame	1		
2	02010285	上摇臂组件左	Front Upper Swing Arm(Left)	1		
3	02010287	下摇臂组件左	Front Lower Swing Arm(Left)	1		
4	02010286	上摇臂组件右	Front Upper Swing Arm(Right)	1		
5	02010288	下摇臂组件右	Front Lower Swing Arm(Right)	1		
6	02030074	前转向角 (左)	Front Steering Angle L.	1		
7	02030075	前转向角 (右)	Front Steering Angle R.	1		
8	020400047	前轮毂座组件	Front Wheel Hub ASSY	2		
9	09010019	网格大灯	Headlight	2		
10	09020042	前左转向灯	Left Turning Light (F.)	2		
11	09020043	前右转向灯	Right Turning Light (F.)	2		
12	04020011	(前) 碟刹盘128	Front Brake Disc(128)	2		
13	12030021	轴承6903	Bearing 6903	2		
14	02010313	前护杠	Front Protection Bars	1		
15	09020086	后左转向灯	Left Turning Light (R.)	1		
16	09020087	后右转向灯	Right Turning Light (R.)	1		
17	06990028	转角橡胶套	Rubber Sleeve for Steering Angle	4		
18	00608013	转向灯灯泡 (无色)	Turn Light Bulb	7		
19	00608003	大灯灯泡 (双爪大头)	Headlight Bulb	2		
20	12030023	轴承6203	Bearing 6203	2		
21	12030014	轴承6204	Bearing 6204	2		
22	12040009	油封	Oil Seal	2		
23	07990004	缓冲衬套	Bushing	16		
24	14010016	前轮毂座	Front Wheel Hub	2		
25	02010976	方向柱固定支架	Steering Wheel Stationary Shaft	1		

### 车架附件 Frame Accessories





12

序	件 号	中文名称	英文名称	数量	单价	
NO.	Code name	Chinese	Description	Q'ty	¥	\$
1	02010309	装饰灯支架	Fog Light Bracket	1		
2	02010312	消声器支架	Muffler Bracket	1		
3	02010315	手把套固定架	Handlebar Holder	1		
4	02010310	电瓶固定压板	Battery Fixed Plate	1		
5	02010331	吊架衬管	Screened Pipe	1		
6						
7	10020009	把套	Handlebar Grip	2		
8	02010316	平衡杆组件	Balancing Lever Assy	2		
9	02010745	换挡拉线固定板	Shift Cable Fixing Plate	1		
10	02010749	换档摇臂	Shift Rocker Arm	2		
11	06020014	撑杆橡塑套	Plastic Sleeve	1		
12	06020157	φ32管塞		2		

车架附件 Frame Accessories

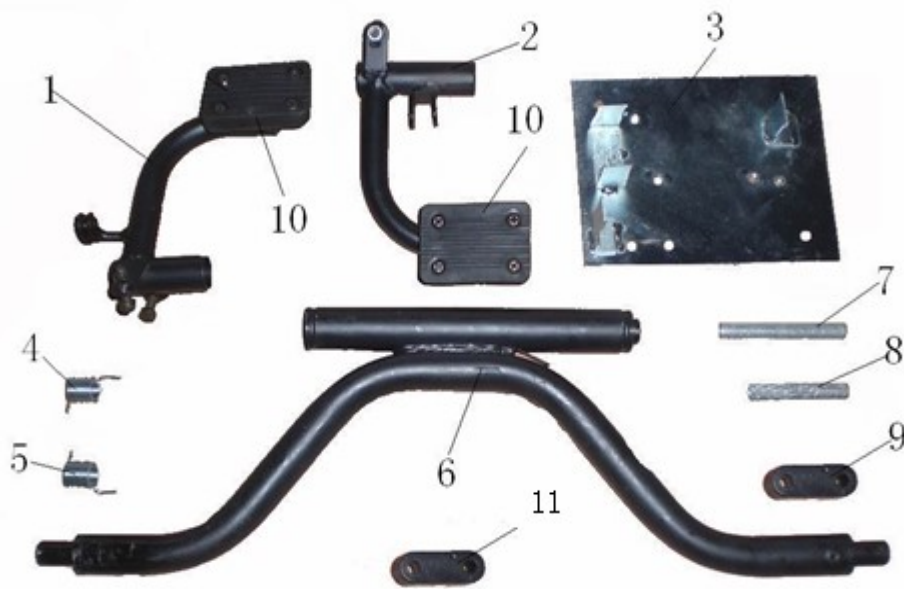

序	件号	中文名称	英文名称	数量	单价	
NO.	Code name	Chinese	Description	Q'ty	¥	\$
1	02010323	油门踏板组件	Accelerator Pedal	1		
2	02011576	刹车踏板组件	Brake Pedal	1		
3	02010311	电器盒固定板组件	Fixed plate of the electrical box	1		
4	07020025	脚刹踏板扭簧	Torsional spring for the brake pedal	1		
5	07020026	油门踏板扭簧	Torsional spring for the accelerator pedal	1		
6	02010318	平衡摇臂组件	Balance arm Assy	1		
7	02010326	刹车杆内衬套	Neck Bush for Brake Lever	1		
8	02010324	油门杆内衬套	Neck Bush for Throttle Lever	1		
9	02030072	方向把卡子	Clip of the Handlebar	1		
10	06990015	脚刹踏板防滑套	Brake pedal Shoe	2		
11	02030073	方向把卡座	Handlebar Fixed Seat	1		

**消声器/车架附件 Frame accessories, Muffler**

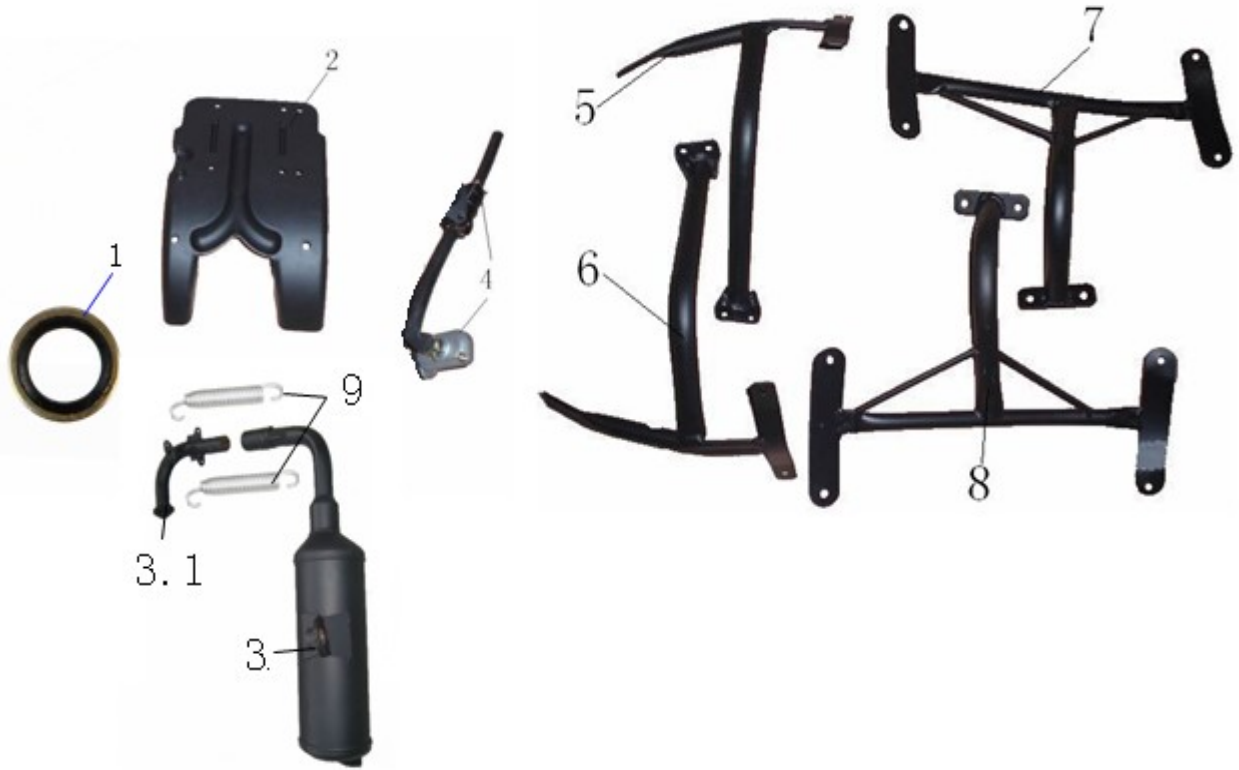

序	件号	中文名称	英文名称	数量	单价	
NO.	Code name	Chinese	Description	Q'ty	¥	\$
1	01990024	排气管垫	Gasket for Exhaust pipe	1		
2	03030229	链罩	Chain Guard	1		
3	01050015-2	消声器	Muffler	1		
3.1	01050015-1	消声器前管	Exhaust pipe	1		
4	01990001	二次补气装置（简易）	Second Adding Air Device(Simple)	1		
5	02010303	前挡泥板支架（左）	Bracket of Front Fender(L.)	1		
6	02010304	前挡泥板支架（右）	Bracket of Front Fender(R.)	1		
7	02010306	后挡泥板支架（左）	Bracket of Rear Fender(L.)	1		
8	02010307	后挡泥板支架（右）	Bracket of Rear Fender(R.)	1		
9	07020102	消声器拉簧	Tension spring	2		

## 棚架/后托架 Roll Bar, Engine carrier



序 NO.	件 号 Code name	中文名称 Chinese	英文名称 Description	数量 Q'ty	单价	
					¥	\$
1	02011570	后坐垫支架	Rear Seat bracket	1		
2	02010295	篷架(前)	Front Top Roof	2		
3	02011574	篷架(后)	Top Roof (Rear)	1		
4	02010283	发动机托架	Engine Bracket	1		
5	02010820	后装饰网罩	Rear Net Protector	1		
6	07990003	缓冲衬套 φ30*φ10*35	Bushing φ30*φ10*35	2		
7	02010321	特制垫片	Gasket	4		
8	02011573	棚架连接管	Rollbar connect Rod	3		
9	02011571	棚架(中前)	Front Crossrange Rollbar	1		
10	02011572	棚架(中后)	Rear Crossrange Rollbar	1		

## 后轴 Rear Axle ASSY

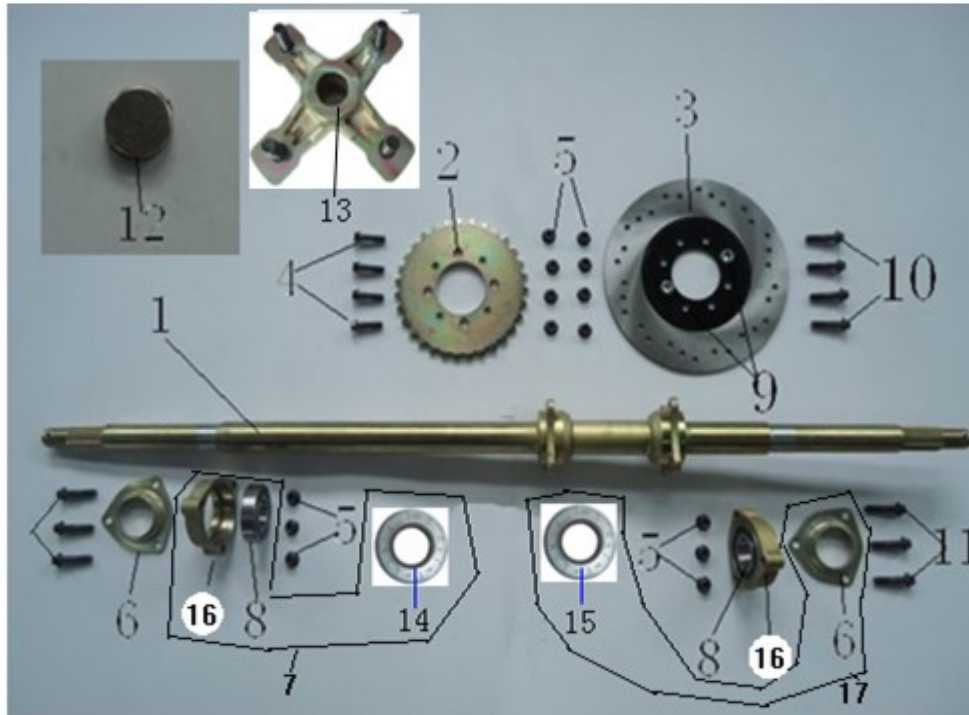

序	件号	中文名称	英文名称	数量	单价	
NO.	Code name	Chinese	Description	Q'ty	¥	\$
1	02040048	后桥轴	Rear Axle	1		
2	02040038	链盘 (牙盘530-31)	Chain plate(530-31)	1		
3	04020009	(后)碟刹盘220*58	Rear Brake Disc(220*58)	1		
4	M8*30	六角法兰面螺栓	Hexagon Bolt with Flange (M8*30)	4		
5	M8*1.25	六角法兰面自锁螺母	Hexagon Locking-Nuts with Flange (M8*1.25)	14		
6	02040009	轴承座防尘盖	dust cap for the bearing pedestal	2		
7	02040051	轴承座组件	Bearing Pedestal	2		
8	12030063	轴承NJ1007M	Bearing NJ1007M	2		
9	02010240	磁钢座	Magnetic Steel Seat	2		
10	M8*25	六角法兰面螺栓	Hexagon Bolt with Flange M8*25	4		
11	M8*40	六角法兰面螺栓	Hexagon Bolt with Flange (M8*40)	6		
12	10990004	磁钢	Magnetic Steel	2		
13	02040105	后轮毂座组件	Rear Hub Seat	2		
14	12040014	油封 $\phi 50 \times \phi 34 \times 7$	Oil seal $\phi 50 \times \phi 34 \times 7$	2		
15	12040015	油封 $\phi 42 \times \phi 30 \times 7$	Oil Seal $\phi 42 \times \phi 30 \times 7$	2		
16	02040008	轴承座	Bearing Seat	2		
17	02040198	轴承座防尘盖组件	Bearing seat Dust Cover	2		



电器/线束 Electrical Components, Cable



序	件号	中文名称	英文名称	数量	单价	
NO.	Code name	Chinese	Description	Q'ty	¥	\$
1	08020235	手刹线	Brake line	1		
2	08020237	油门线	Throttle cable	1		
3	08020236	换档拉线	Shift cable	2		
4	08010113	电缆线	Leader cable	1		
5	08010113-1	副电缆	Vice-cable	1		
6	09040004	三星装饰灯	Fog Light	3		
7	09030016	尾灯	Left Turning Light(R.)	2		
8	03990019	篷架帆布500*210	Right Turning Light(R.)	4		
9	03990020	(网罩)装饰网布	Taillight	1		
10	00608009	刹车灯无色灯泡	Brake light Bulb	2		

电器/开关 Electrical components, Switches



序	件号	中文名称	英文名称	数量	单价	
NO.	Code name	Chinese	Description	Q'ty	¥	\$
1	03030228	仪表板	Instrument Board	1		
2	10050021	指示灯表	Light Indicator	1		
3	10070005	高低音喇叭	Compound Horn	1		
4	10080018	电门锁	Lock	1		
5	01020041	CM6321继电器	CM6321 Relay	1		
6	01020021	继电器	Relay	1		
7	01020016	点火器	Igniter	1		
8	01020022	高压包	Ignition Coil	1		
9	01020017	整流器	Rectifier	1		
10	10050020	液晶车速里程表	Odometer	1		
11	01020011	闪光器	Flasher	1		
12	10040020	车速感应器	Mileage Inductor	1		
13	10010007	变光开关	Dimmer Switch	1		
14	10010021	大灯开关	Headlight Switch	1		
15	10010002	喇叭开关	Horn Switch	1		

16	10010005	转向灯开关	Switch of Turning Light	1		
17	10010006	警示灯开关	Caution Light Switch	1		

**转向/换挡 Steering system, Gear shift system**



序	件号	中文名称	英文名称	数量	单价	
NO.	Code name	Chinese	Description	Q'ty	¥	\$
1	020300338	转向器拉杆（带球头）	Steering Linkage (with Ball)	2		
2	02010253	方向机压板	Redirector Fixed Plate	2		
3	03030233	拨档器塑件组合	Shifter Plastic Part Assy	1		
4	02990002	17轴用卡簧	Circlip 17	1		
5	02030339	方向器	Redirector	1		
6	02030078	万向节L:502	Gimbal L:502	1		
7	07020028	拨档器扭簧	Torsional Spring	1		
8	02030077	方向盘固定轴	Steering Wheel Fixed Shaft	1		
9	02010329	拨档器固定板组件	Shifter Dead Plate Assy	1		
10	03030406	工具箱	Tool Box	1		
11	06990029	胶木手柄（换挡用）	Hand Shank	1		
12	02010842	拨档杆组件	gear lever assy	1		
13	12020008	摇臂全铁防尘盖	Iron Dust Cover Rocker Arm	1		

14	12060022	球头 (10*1.25倒牙)	Ball Joint (M10*1.25)	2		
15	190399	转向拉杆L:280MM	Steering Rod L: 280mm	2		

油箱/轮胎 Fuel Tank, Wheel



序	件号	中文名称	英文名称	数量	单价	
NO.	Code name	Chinese	Description	Q'ty	¥	\$
1	12020002-XP	(腹板) 轮毂防尘盖 (48)	Dust cover of the hub(48)	2		
2	12020003-XP	(铝合金) 轮毂防尘盖	Dust Cover 48 (ABS)	4		
3	190015	气门嘴	Cycle Valve	4		
4	06990005	篷架橡塑外套	Rubber Sheath 28*55*500	4		
5	09060011	后视镜	Rearview Mirror	1		
6	10060003	油箱开关	Fuel tank Switch	1		
7	05030011	油箱	Fuel tank	1		
8	10990005	电瓶12V9A-BS (立式)	Battery 12V9A-BS(Vertical type)	1		
9	06010007	轮胎21*7-10	Tyre(21*7-10)	2		
10	06010008	轮胎22*10-10	Tyre(22*10-10)	2		
11	02040208	(腹板) 钢圈 (10*5.5)	Steel Rim (10*5.5)	2		

11	02040028-XP	2	Alloy Rim 10*5.5	2		
12	02040209	(腹板) 钢圈 (10*8.0)	Steel Rim (10*8.0)	2		
	02040030-XP	铝轮10*8.0	Alloy Rim 10*8.0	2		
13	12020004	摇臂橡胶防尘盖M10	Dust Cover of the Rocker arm M10	2		
14	06020013	油箱缓冲垫 (带衬套)	Crash Pad	4		
15	05050004	油箱盖	Fuel Tank Cap	1		
16	05050007	滤网	Filter Meshing	1		
17	10040059	油位传感器	Fuel Gauge	1		

### 减震器 Shock



序	件号	中文名称	英文名称	数量	单价	
NO.	Code name	Chinese	Description	Q'ty	¥	\$
1	07010039	前减震	Front Shock Absorber	2		
2	07010038	后减震	Rear Shock Absorber	2		
3	05020005	坐垫滑轨	Sliding Rail (for the seat)	1		
4	02030056	方向盘 (300)	Steering Wheel	1		
5	04990002	手刹器 (直角)	Hand Brake	1		

6	02040159	链条530	Chain530	52节		
7	02040160	530链条接头	Chain master 530	1		

坐垫/其他 Seat



序 NO.	件号 Code name	中文名称 Chinese	英文名称 Description	数量 Q'ty	单价	
					¥	\$
1	03030231	电器盒	Electric box	1		

2	01040012	空滤器	Air Filter	1	
3	03030230	后轮挡泥板(150加宽)	Rear Fender	2	
4	03030036	(借用)后轮挡泥板430*185	Front Fender(430*185)	2	
5	09050001	方反光片	Reflector	2	
6	06990001	二级过滤器	Secondary filter	1	
7	12010007	油管夹8.8	Tubing clamp 8.8	4	
8	06030002	汽油管4.5*8.5	Gasoline pipe(4.5*8.5)	34cm	
9	05020002	安全带(带螺栓)	Safety Belt(with Bolt)	2	
10	05010016	座垫(左)	Seat (L.)	1	
11	05020017	座垫(右)	Seat (R.)	1	
12	190098	滤芯	Filter Foam	1	
13	05010068	座垫(小)	Rear Seat	2	

### 碟刹 Disc Brake

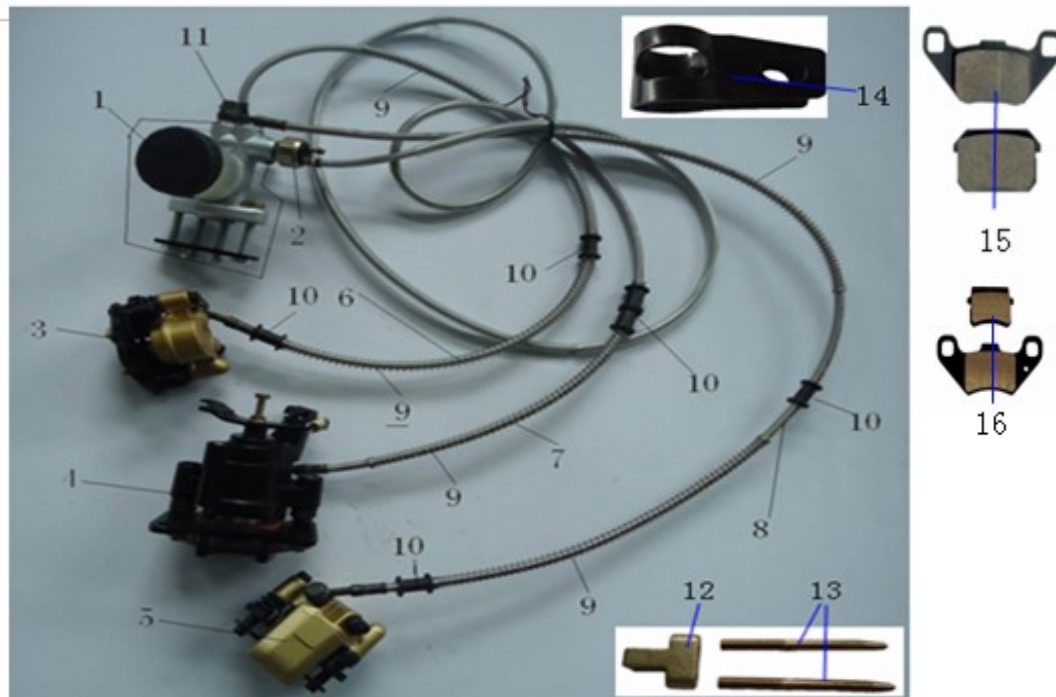

序	件号	中文名称	英文名称	数量	单价
---	----	------	------	----	----

NO.	Code name	Chinese	Description	Q'ty	¥	\$
	04010090	碟刹总成	Disc Brake Assy	1		
1	190035	外挂油杯总泵 (圆油杯)	Brake Master Pump	1		
2	190025	圆形液压开关	Brake indicator Light Switch	1		
3	190018	圆弧AG左泵	Left Brake Caliper	1		
4	190020	05机械泵	Machnic Caliper	1		
5	190019	圆弧AG右泵	Right Brake caliper	1		
6	190387	前左制动油管 840mm	Front Brake Line(L.)	1		
7		后制动油管 mm	Rear Brake Line	1		
8	190388	前右制动油管 1100mm	Front Brake Line(R.)	1		
9		防护弹簧	Spring	5		
10		滑动固定套	Sliding fixing Sleeve	6		
11		特殊螺栓	Special bolt	6		
12	190196	顶杆固定件	Fixed part of the Mandril	1		
13	190197	顶杆M8*70 (带1螺母)	Knock out Pin	2		
14	12990004	碟刹管线夹	Pipeline Clamp	6		
15	190010	F035摩擦片	Brake Pad F 035	1付		
16	190009	F18A摩擦片	Brake Pad F18A	2付		

### 随车工具 Tools Kit

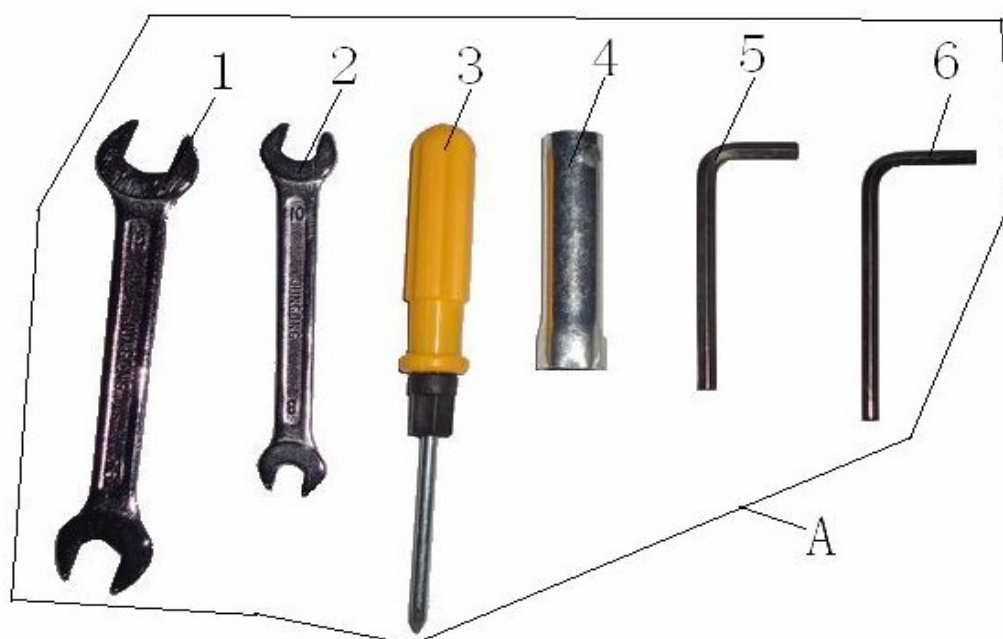



序	件号	中文名称	英文名称	数量	单价	
NO.	Code name	Chinese	Description	Q'ty	¥	\$
A		随车工具	Tools	1		
1	16010005	开口扳手12-14	Open Spanner(12-14)	1		
2	16010004	开口扳手8-10	Open Spanner(8-10)	1		
3	16010006	双头螺丝刀	Dual-Purpose Screwdriver	1		
4	16010007	火花塞套筒S=16	Spark Plug Box Spanner(S=16)	1		
5	16010002	内六角扳手6mm	Socket Head Wrench(6mm)	1		
6	16010001	内六角扳手5mm	Socket Head Wrench(5mm)	1		

本次更改主要是涉及刹车踏板组件编码错误的更换，及增加副电缆线编码，2017-03-24