

# DF200GKF零件目录图册

## DF200GKF PARTSLIST



### **FOREWORD**

When you are going to order parts you may take this booklet as reference but any differences please take the reality on vehicle as standard.

To find out the name, Item code or fitment you may check in the illustration with the size and appearance .Then with the no. in the illustration you will find out the name, item code and quantity.

There will no notice to you ahead of any change of the information in this booklet.

发动机、化油器 Engine Carburetor

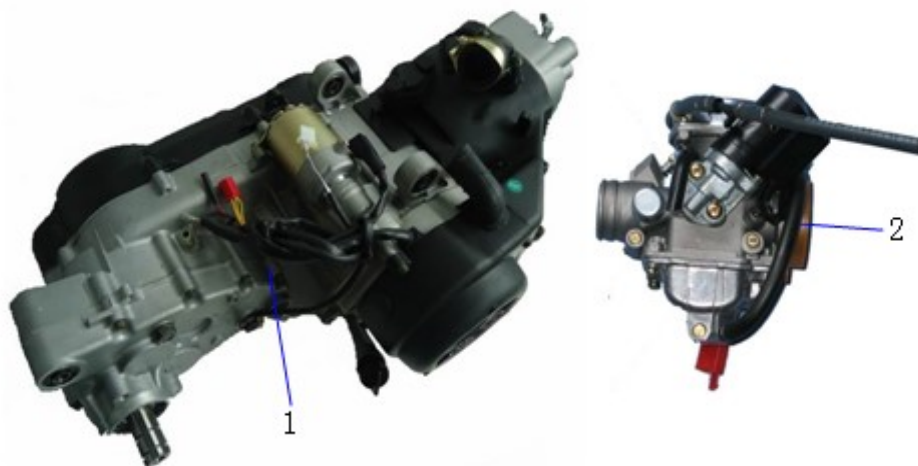

序 NO.	件 号 Code name	中文名称 Chinese	英文名称 Description	数量 Q'ty	单价 ¥	单价 \$
1	01010002	发动机	Engine	1		
2	01030012	化油器	Carburetor	1		

曲轴箱总成(一) Crankcase Assy

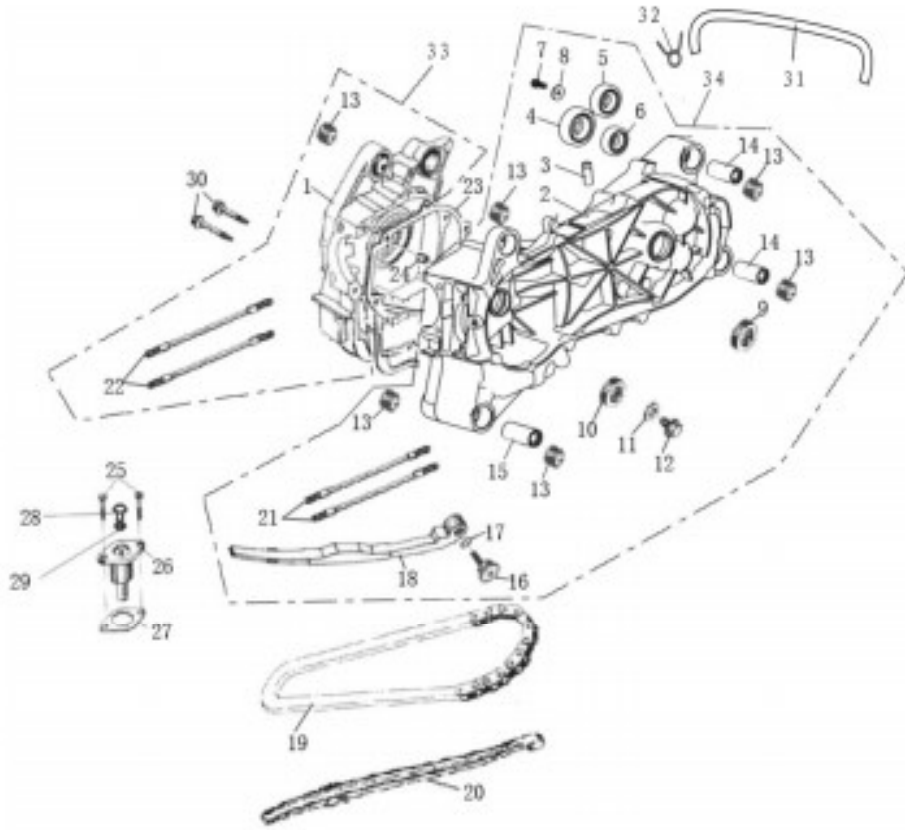

序 NO.	件号 Code name	中文名称 Chinese	英文名称 Description	数量 Q'ty	单价 ¥	单价 \$
1	2. 20. 05. 09. 02000	右箱体	R.Crankcase Assembly	1		
2	2. 20. 04. 66. 07000	左箱体本体总成	L.Crankcase Assembly	1		
3	1. 20. 07. 32. 12000	通气管接头	Breather Pipe Joint	1		
4	1. 00. 01. 6204	轴承6204	Bearing 6204	1		
5	1. 00. 01. 6203	轴承6203	Bearing 6203	1		
6	1. 00. 01. 6202	轴承6202	Bearing 6202	1		
7	1. 05. 01. 09. 0612	螺栓M6×12	Bolt M6×12	1		
8	1. 20. 20. 20. 17000	大垫圈6	Washer 6	1		
9	1. 20. 20. 01. 08000	输入轴油封20×32×6	Oil-Seal 20×32×6	1		
10	1. 20. 04. 01. 13000	曲轴油封19.8×30×5	Oil-Seal 19.8×30×5	1		
11	1. 20. 04. 01. 03000	平垫 12×18×1	Gasket 12×18×1	1		
12	1. 20. 04. 01. 14000	放油螺栓M12×1.5×14	Bolt M12×1.5×14	1		
13	1. 20. 04. 01. 09000	前减震套	Front Shock Absorber Sheath	5		
14	1. 20. 04. 65. 15000	衬套42	Bush 42	2		
15	1. 20. 04. 65. 16000	衬套50	Bush 50	1		

16	1. 20. 13. 01. 01000	固定拉力杆螺钉	Screw	1		
17	1. 20. 13. 01. 02000	O形圈16×1.5	O-Ring 16×1.5	1		
18	1. 20. 13. 01. 05000	拉力杆	Tension Rod	1		
19	1. 20. 13. 32. 04000	正时链条	Timing Chain	1		

### 曲轴箱总成 (二) Crankcase Assy

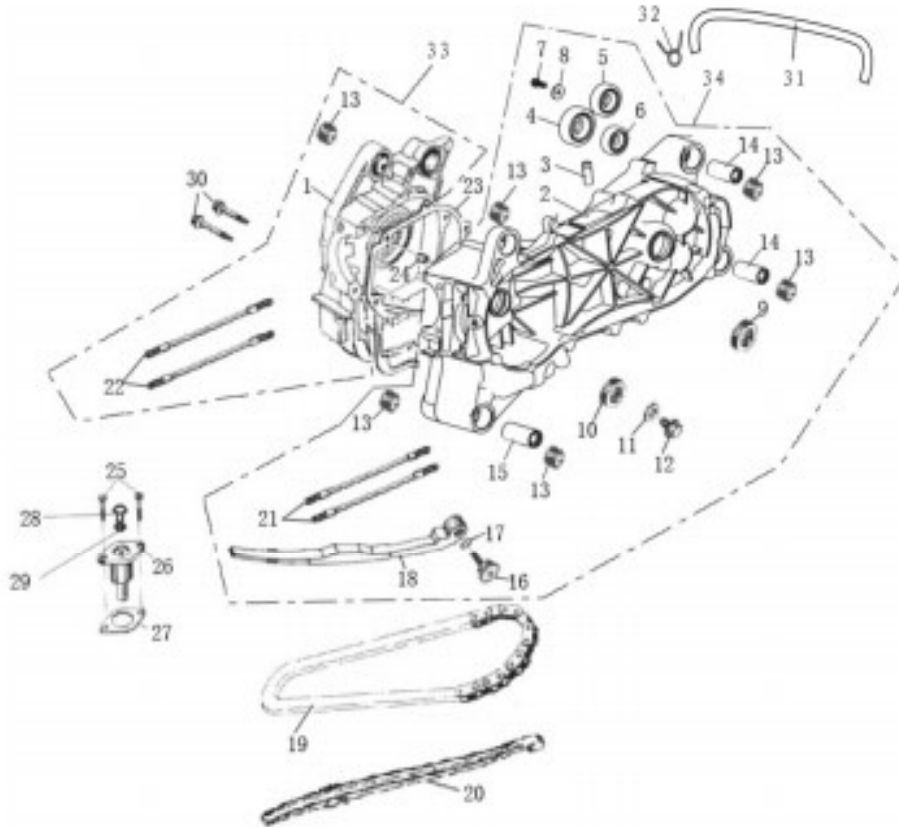

序 NO.	件 号 Code name	中文名称 Chinese	英文名称 Description	数量 Q'ty	单价 ¥	单价 \$
20	1. 20. 13. 01. 06000	分气链条导件	Chain Guide	1		
21	1. 20. 04. 06. 04000	双头螺柱M8×209	Stud bolt M8×209	2		
22	1. 20. 05. 06. 01000	双头螺柱M8×201	Stud bolt M8×201	2		
23	1. 20. 04. 01. 05000	右箱体垫	Gasket	1		
24	1. 20. 04. 01. 01000	定位套 ø8×14	Locating Bush ø8×14	2		
25	1. 05. 01. 09. 0622	螺栓M6×22	Bolt M6×22	2		
26	1. 20. 13. 01. 07000	压链器	Chain Adjuster	1		
27	1. 20. 13. 01. 03000	压链器纸垫	Gasket	1		
28	1. 20. 13. 01. 08000	扁头螺钉	Screw	1		
29	1. 20. 13. 01. 09000	O形圈9.5*1.5	O-Ring 9.5*1.5	1		
30	1. 05. 01. 09. 0650	螺栓M6×50	Bolt M6×50	2		
31	1. 20. 04. 65. 12000	变速箱通气管	Gearcase Breather Pipe	1		
32	1. 20. 04. 65. 17000	卡箍11.5	Clamp 11.5	1		
33	2. 20. 05. 67. 99000	右箱体总成	R.Crankcase Assembly	1		

34	2. 20. 04. 66. 99000	左箱体总成	L.Crankcase Assembly	1		

**变速箱盖总成(一) Gearcase Assy**

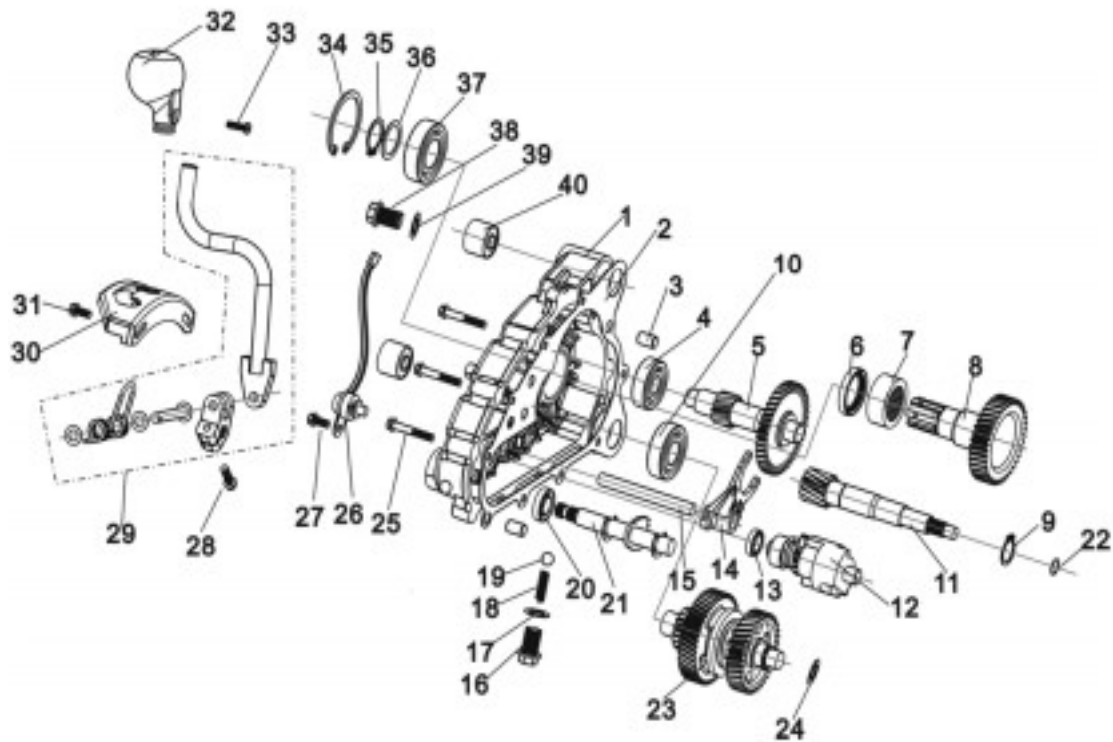

序 NO.	件 号 Code name	中文名称 Chinese	英文名称 Description	数量 Q'ty	单价 ¥	单价 \$
1	2. 20. 20. 65. 01000	变速箱盖	Gearcase cover	1		
2	1. 20. 20. 65. 08000	变速箱盖垫片	Gearcase Gasket	1		
3	1. 20. 01. 01. 01000	定位套	Locating Bush	2		
4	1. 00. 01. 6302	轴承6302	Bearing 6302	1		
5	1. 20. 20. 65. 10000	倒档齿轮轴组	Reverse Gear Shaft Assy	1		
6	1. 20. 20. 65. 14000	输出轴油封	Oil Seal of Output Shaft	1		
7	1. 00. 01. 4905	滚针轴承RNA4905	Needle Bearing RNA4905	1		
8	1. 20. 20. 65. 03000	输出轴	Output Shaft	1		
9	1. 05. 06. 02. 2000	轴用挡圈20	Check Ring 20	1		
10	1. 00. 01. 6204	轴承6204	Bearing 6204	2		

11	1. 20. 20. 65. 02000	变速箱输入轴	Input Shaft	1		
12	1. 20. 20. 65. 18000	变档鼓组件	Shift Drum Assy	1		
13	1. 20. 20. 65. 19000	变档鼓油封	Oil Seal	1		
14	1. 20. 20. 65. 11000	拨叉	Shift Fork	1		
15	1. 20. 20. 65. 21000	拨叉轴	Shift Rail	1		
16	1. 20. 04. 65. 18000	空心螺栓	Hollow Bolt	1		
17	1. 20. 04. 65. 19000	垫圈14×22×1	Washer 14×22×1	1		
18	1. 20. 04. 65. 20000	限位弹簧	Limit Spring	1		
19	1. 20. 04. 65. 21000	钢球13/32	Steel Ball	1		

### 变速箱盖总成 (二) Gearbox Cover Assy

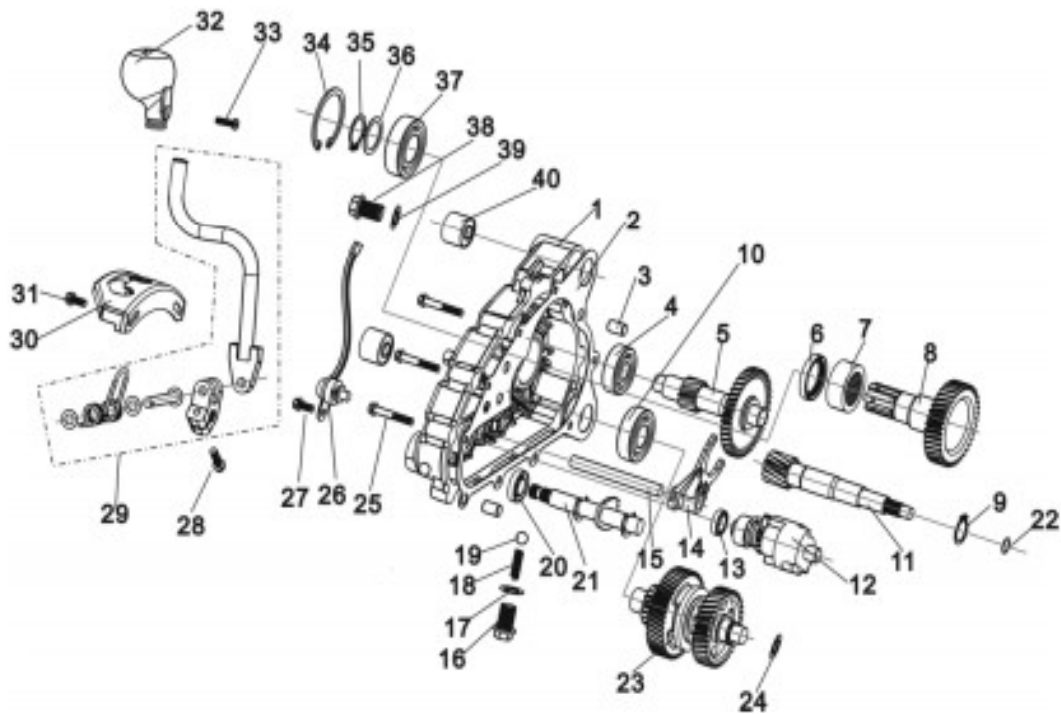

序	件号	中文名称	英文名称	数量	单价	单价
NO.	Code name	Chinese	Description	Q'ty	¥	\$
20	1. 20. 20. 65. 16000	换档轴油封	Oil Seal of Shift Shaft	1		
21	1. 20. 20. 65. 17000	换档轴组件	Shift Shaft Assy	1		
22	1. 20. 20. 65. 20000	O形圈10×2.5	O-Ring 10×2.5	1		
23	1. 20. 20. 65. 09000	中间齿轮轴组	Intermediate Gear Shaft	1		
24	1. 20. 04. 65. 23000	垫圈15×19×1	Washer 15×19×1	1		
25	1. 05. 01. 09. 0640	螺栓M6×40	Bolt M6×40	10		
26	1. 20. 32. 65. 08000	档位传感器组件	Gear Sensor Module	1		
27	1. 05. 01. 09. 0612	螺栓M6×12	Bolt M6×12	1		
28	1. 05. 01. 08. 0622	螺栓M6×22	Bolt M6×22	1		
29						

30						
31						
32						
33						
34	1.05.06.01.5200	孔用挡圈52	Check Ring 52	1		
35	1.05.06.02.2500	轴用挡圈25	Check Ring 25	1		
36	1.20.04.65.22000	垫圈25×33×1	Washer 25×33×1	1		
37	1.00.01.6205-2RS	轴承6205-2RS	Bearing 6205-2RS	1		
38	1.20.04.01.14000	放油螺栓M12×1.5×14	Bolt M12×1.5×14	1		
39	1.20.04.01.03000	平垫 12×18×1	Gasket 12×18×1	1		
40	1.20.04.01.09000	前减震套	Front Shock Absorber	2		

**左盖总成 Left Cover Assy**

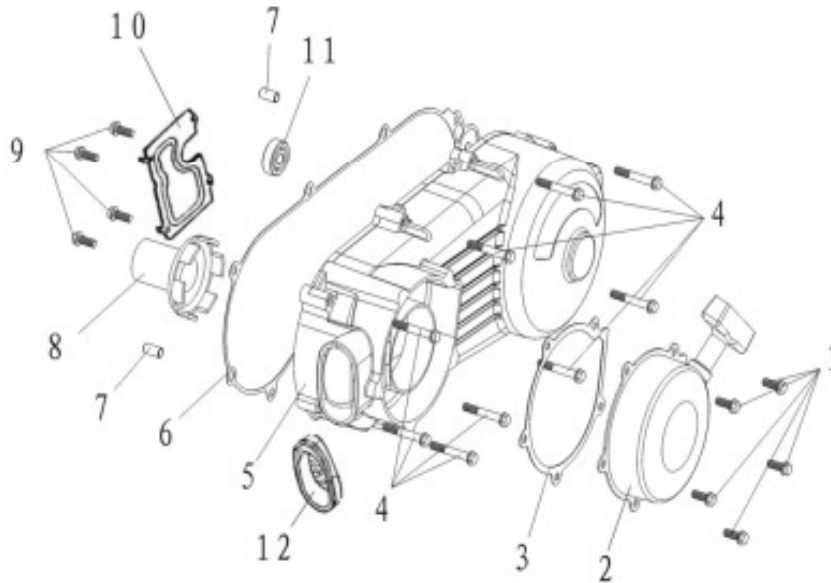

序 NO.	件 号 Code name	中文名称 Chinese	英文名称 Description	数量 Q'ty	单价 ¥	单价 \$
1						
2						
3						
4	1.05.01.09.0640	螺栓M6×40	Bolt M6×40	8		
5	2.20.06.65.01001	左盖	Left Cover	1		
6	1.20.06.01.07000	左盖垫	Left Cover Gasket	1		
7	1.20.04.01.01000	定位套 ø8×14	Locating Bush ø8×14	2		
8						
9	1.05.02.03.4208	自攻螺钉ST4.2×8	Tapping Screw ST4.2×8	4		
10	1.20.06.01.03000	通气导板	Breather Guide Plate	1		

11	1.00.01.6200-2RS	轴承6200-2RS	Bearing 6200-2RS	1		
12	1.20.06.01.10001	吸风口罩	Cover of Exhaust Opening	1		

**右箱体端盖总成 Right Cover Assy**

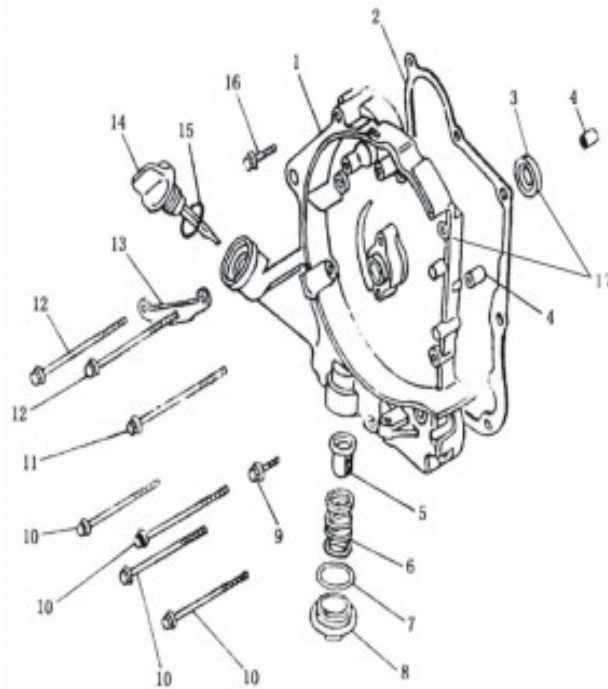

序	件号	中文名称	英文名称	数量	单价	单价
NO.	Code name	Chinese	Description	Q'ty	¥	\$
1	2.20.07.01.01000	右盖	Right Cover	1		
2	1.20.07.01.06000	右盖垫	Right Cover Gasket	1		
3	1.20.04.01.13000	曲轴油封19.8×30×5	Oil Seal 19.8×30×5	1		
4	1.20.04.01.01000	定位套φ8×14	Locating Bush φ8×14	2		
5	1.20.07.01.09000	滤油网	Oil-Filter Screen	1		
6	1.20.07.01.03000	滤油网弹簧	Oil-Filter Screen Spring	1		
7	1.20.07.01.04000	O形圈30.5×3	O-Ring 30.5×3	1		



8	1.20.07.01.02000	滤油网螺帽	Oil-Filter Screen Nut	1		
9	1.05.01.09.0632	螺栓M6×32	Bolt M6×32	1		
10	1.05.01.09.0695	螺栓M6×95	Bolt M6×95	4		
11	1.05.01.09.06100	螺栓M6×100	Bolt M6×100	1		
12	1.05.01.09.06110	螺栓M6×110	Bolt M6×110	2		
13	1.20.07.01.08000	触发线卡	Trigger Line Card	1		
14	1.20.07.01.05000	机油尺	Oil Level Gauge	1		
15	1.20.07.01.07000	O形圈18×3	O-Ring 18×3	1		
16	1.05.01.09.0635	螺栓M6×35	Bolt	1		
17	2.20.07.01.99000	右盖总成	Right Cover Assy	1		

气缸体总成 Cylinder Body Assy

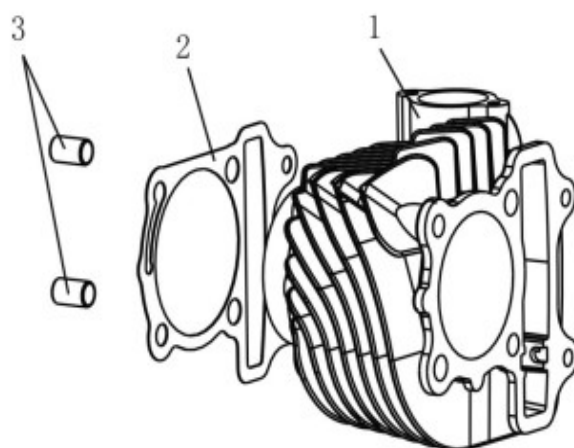

序	件号	中文名称	英文名称	数量	单价	单价
NO.	Code name	Chinese	Description	Q'ty	¥	\$
1	1.20.02.09.03000	气缸体	Cylinder Block	1		
2	1.20.02.09.01000	气缸垫	Cylinder Block Gasket	1		
3	1.20.01.01.01000	定位套 φ10×16	Locating Bush φ10×16	2		

气缸头总成 Cylinder Head Assy

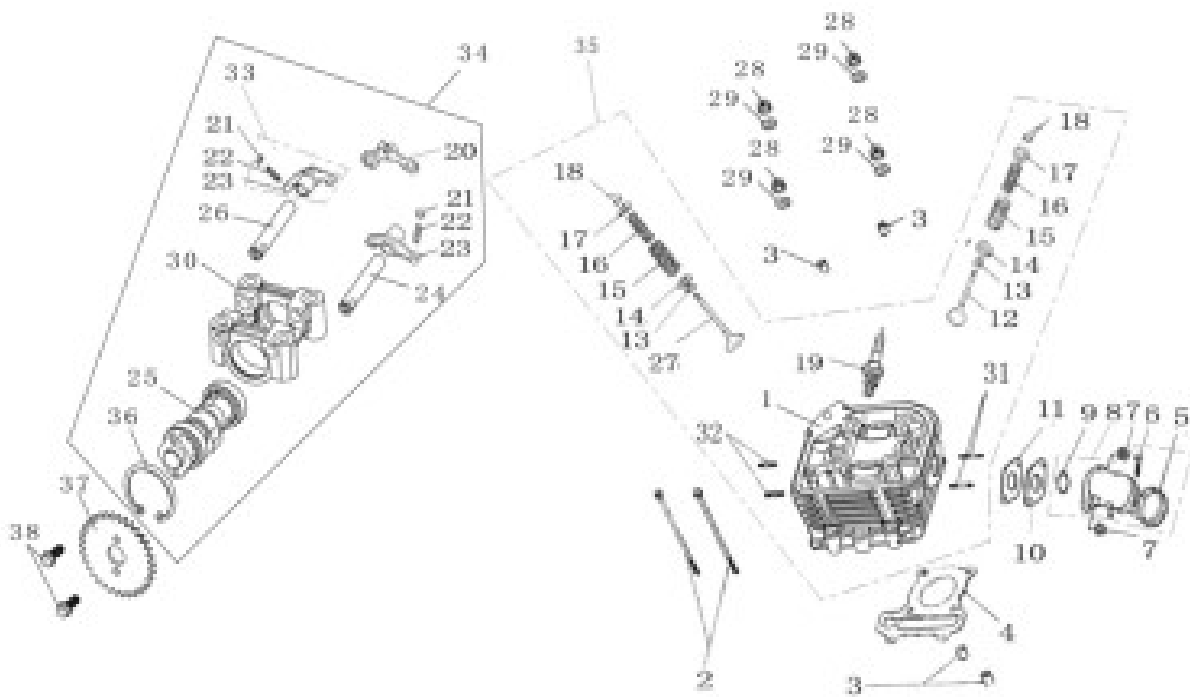

序 NO.	件号 Code name	中文名称 Chinese	英文名称 Description	数量 Q'ty	单价 ¥	单价 \$
1	2. 20. 01. 09. 13000	气缸头组本体 (无补气)	Cylinder Head	1		
2	1. 05. 01. 09. 06100	螺栓M6×100	Bolt M6×100	2		
3	1. 20. 01. 01. 01000	定位套φ10×16	Locating Bush φ10×16	4		
4	1. 20. 01. 09. 15000	气缸头垫片	Cylinder Head Gasket	1		
5	1. 20. 01. 01. 16010	进气管夹	Pipe Clamp	1		

6	1.05.02.01.0425	螺钉M4×25	Screw M4×25	1		
7	1.05.04.02.0600	螺母M6	Nut M6	2		
8	1.20.01.01.16000	进气管总成	Intake-Tube Assy	1		
9	1.00.14.265180	O形圈26.5×1.8	O-Ring 26.5×1.8	1		
10	1.20.01.01.12000	(化油器) 隔热板	Thermal Baffle	1		
11	1.20.01.01.11000	(隔热板) 纸垫板	Base Plate	1		
12	1.20.01.06.06000	进气门	Inlet Valve	1		
13	1.20.01.01.14000	气门油封	Valve Oil Seal	2		
14	1.20.01.01.10000	(气门弹簧) 垫片	Gasket	2		
15	1.20.01.06.09000	气门外弹簧	Outer Valve Spring	2		
16	1.20.01.06.08000	气门内弹簧	Inner Valve Spring	2		
17	1.20.01.01.05000	气门弹簧座	Valve Spring Retainer	2		
18	1.20.01.01.07000	气门锁块	Valve Cotter	4		
19	1.20.01.01.17000	火花塞	Spark Plug	1		
20	1.20.12.01.05000	止动板组	Stop Plate	1		
21	1.20.12.01.04020	调整螺母	Adjusting Nut	2		
22	1.20.12.01.04030	调整螺丝	Adjusting Screw	2		
23	1.20.12.06.04010	(气门) 摇臂	Rocker Arm	2		

### 气缸头总成 (二) Cylinder Head Assy

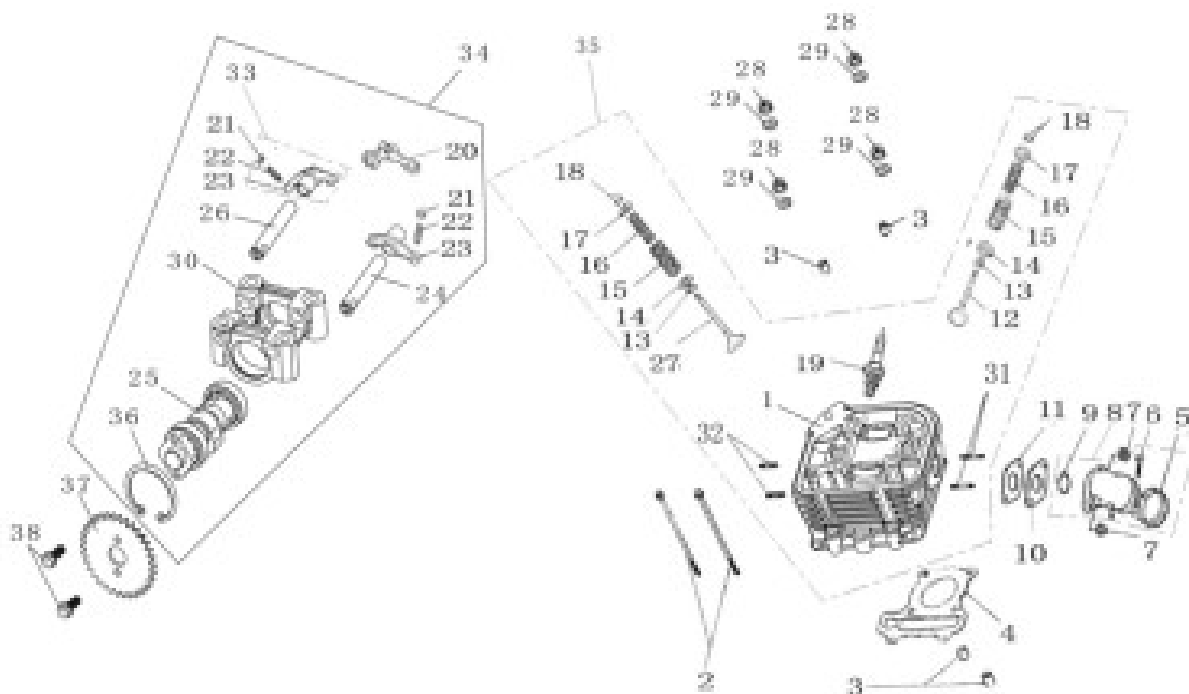

序	件号	中文名称	英文名称	数量	单价	单价
NO.	Code name	Chinese	Description	Q'ty	¥	\$
24	1.20.12.06.03000	进气摇臂轴组	Inlet Rocker Arm Shaft Assy	1		
25	1.20.11.06.01000	凸轮轴总成	Camshaft Assy	1		

26	1. 20. 12. 06. 02000	排气摇臂轴	Inlet Rocker Arm Shaft	1		
27	1. 20. 01. 06. 04000	排气门	Exhaust Valve	1		
28	1. 05. 04. 02. 0800	螺母M8	Nut M8	4		
29	1. 20. 04. 01. 06000	垫圈8	Washer 8	4		
30	2. 20. 12. 06. 01000	凸轮轴座	Camshaft Retainer	1		
31	1. 20. 01. 01. 03000	双头螺柱M6×63	Stud Bolt M6×63	2		
32	1. 20. 01. 08. 02000	双头螺柱M8×32	Stud Bolt M8×32	2		
33	1. 20. 12. 06. 04000	气门摇臂	Valve Rocker	2		
34	2. 20. 12. 06. 99000	凸轮轴座总成	Camshaft Retainer Assy	1		
35	2. 20. 01. 67. 99000	气缸头总成	Cylinder Head Assy	1		
36	1. 05. 06. 01. 3500	孔用挡圈35	Check Ring	1		
37	1. 20. 11. 32. 02000	正时链轮	Timing Sprocket	1		
38	1. 05. 01. 08. 0512	螺栓M5×12	Bolt M5×12	2		

**气缸头盖总成 Cylinder Head Cover Assy**

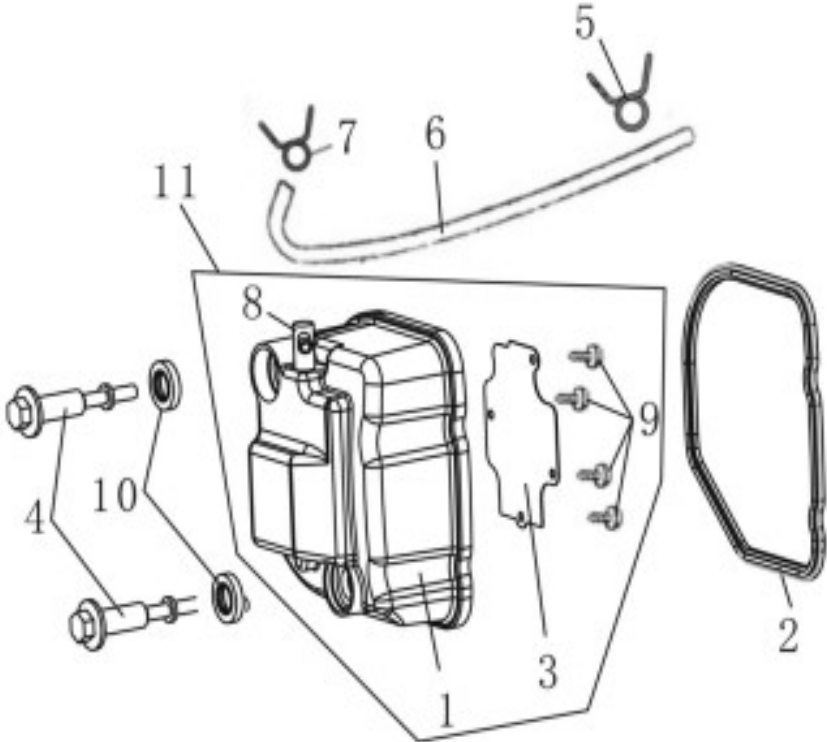

序	件号	中文名称	英文名称	数量	单价	单价
NO.	Code name	Chinese	Description	Q'ty	¥	\$
1	2. 20. 03. 06. 01000	气缸头盖	Cylinder Head Cover	1		
2	1. 20. 03. 06. 03000	气缸盖密封圈	Seal Ring of Cylinder Head Cover	1		
3	1. 20. 03. 01. 02008	盖片	Cover Slip	1		
4	1. 20. 03. 32. 30000	盖罩螺栓	Bolt	2		
5	1. 20. 03. 01. 05010	管夹	Pipe Clamp	1		
6	1. 20. 03. 01. 05000	通气管组	Breather Pipe Assy	1		
7	1. 20. 03. 01. 05020	管夹	Pipe Clamp	1		
8	1. 20. 03. 01. 04000	管接头组件	Pipe Joint Assy	1		
9	1. 05. 02. 03. 4208	自攻螺钉ST4.2×8	Tapping Screw ST4.2×8	4		
10	1. 20. 03. 32. 31000	衬胶垫圈	Rubber Gasket	2		
11	2. 20. 03. 06. 99000	气缸头盖总成	Cylinder Head Cover Assy	1		

曲轴连杆组件、活塞组件 Connecting Rod of Crank-shaft Assy

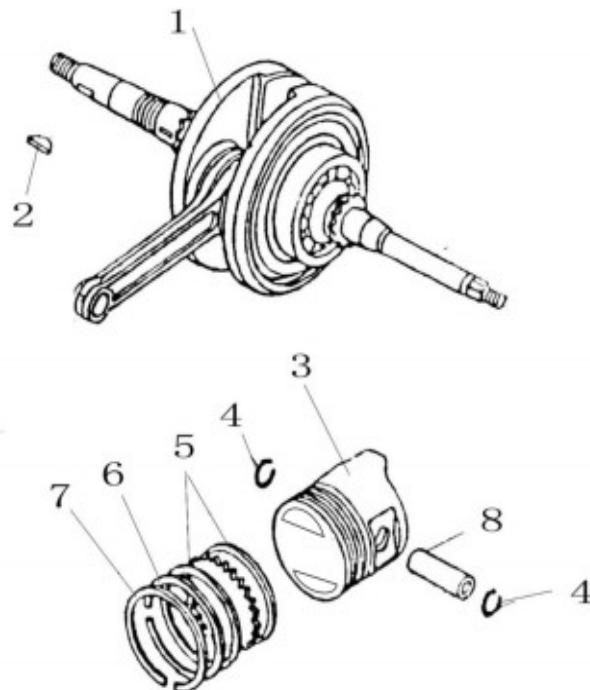

序	件 号	中文名称	英文名称	数量	单价	单价
NO.	Code name	Chinese	Description	Q'ty	¥	\$
1	1. 20. 09. 65. 01000	曲轴连杆组	Connecting Rod of Crank-shaft	1		
2	1. 20. 09. 01. 01010	半圆键	Woodruff Key	1		
3	1. 20. 10. 08. 01000	活塞	Piston	1		
4	1. 20. 10. 01. 04000	活塞销卡簧	Clamp Spring	2		
5		油环组合(含刮片环)	Oil Ring			
6		第二道气环	Piston Ring 1			
7		1. 20. 10. 08. 02000	第一道气环			
8	1. 20. 10. 08. 03000	活塞销	Piston Pin	1		

**起动电机总成 Starting Motor Assy**

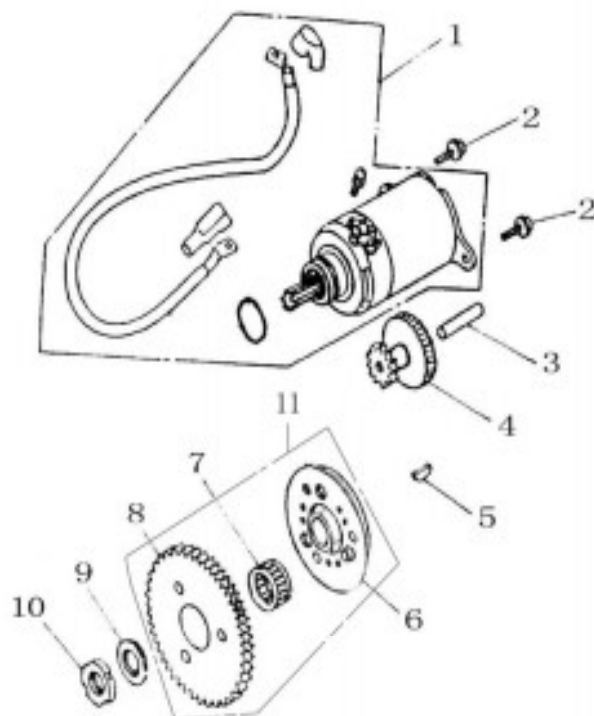

序	件号	中文名称	英文名称	数量	单价	单价
NO.	Code name	Chinese	Description	Q'ty	¥	\$
1	1.20.18.01.01000	起动电机总成	Starter Motor Assy	1		
2	1.05.01.09.0616	螺栓M6×16	Bolt M6×16	2		
3	1.20.18.01.02000	齿轮轴	Gear Shaft	1		
4	1.20.18.01.03000	过渡齿轮	Transition Gear	1		
5	1.20.09.01.01010	半圆键	Woodruff Key	1		
6	1.20.19.08.01020	超越离合器组件	Overrunning Coupler Assy	1		
7	1.20.19.01.01040	滚针轴承	Needle Bearing	1		
8	1.20.19.03.01030	从动齿轮组合	Driven Gear Assy	1		
9	1.20.19.01.03000	垫片	Gasket	1		
10	1.20.19.01.02000	锁紧螺母SM22×1左	Locknut SM22×1 (L.)	1		
11	1.20.19.08.01000	起动超越离合器	Overrunning Coupler	1		

**主、从动皮带轮总成 Driving and Driven Pulley Assy**

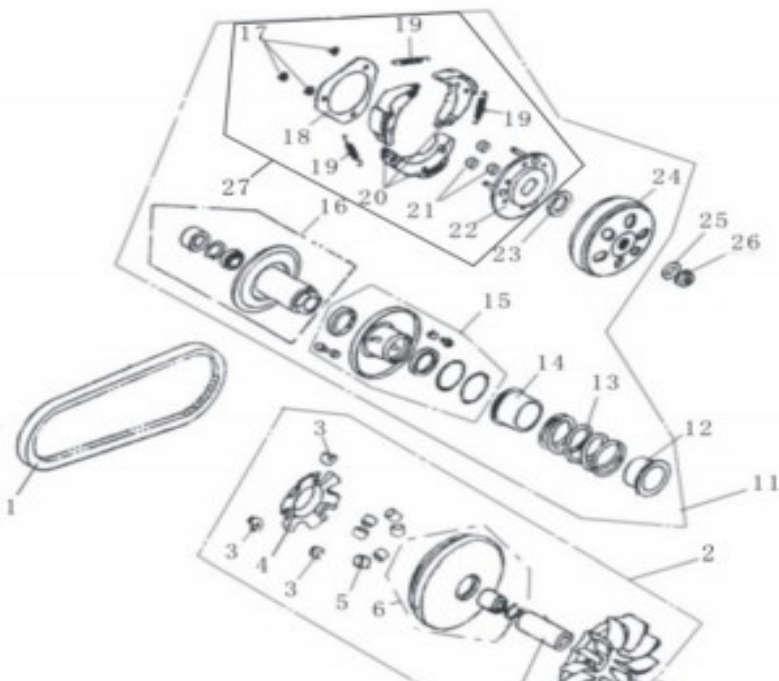

7  
8  
9 10

序	件号	中文名称	英文名称	数量	单价	单价
NO.	Code name	Chinese	Description	Q'ty	¥	\$
1	152019000	齿形三角皮带743-20-30	Tooth Belt	1		
2	1.20.21.01.01000	主动皮带轮总成	Driving Pulley Assy	1		
3	1.20.21.01.01060	琅块	Piece	3		
4	1.20.21.01.01050	拖动法兰	Drag Flange	1		
5	1.20.21.01.01040	离心滚柱	Right Capstan Assy	6		
6	1.20.21.01.01030	右主动轮组合	Right Capstan Assy	1		
7	1.20.21.01.01020	衬套	Bush	1		
8	1.20.21.01.01010	驱动皮带扇叶盘	Driving Belt Fan	1		
9	1.20.17.65.03001	垫圈12.5×25×7	Washer 12.5×25×7	1		
10	1.05.04.10.1213	螺母M12×1.25 H=10	Nut M12×1.25 H=10	1		
11	1.20.22.01.01000	从动皮带轮总成	Follower Pulley Assy	1		
25	1.05.05.04.1200	垫圈12.3×29×2.5	Washer 12.3×29×2.5	1		
26	1.05.04.10.1212	螺母M12×1.25 H=8	Nut M12×1.25 H=8	1		

磁电机部件、机油泵部件 Magneto and Oil pump

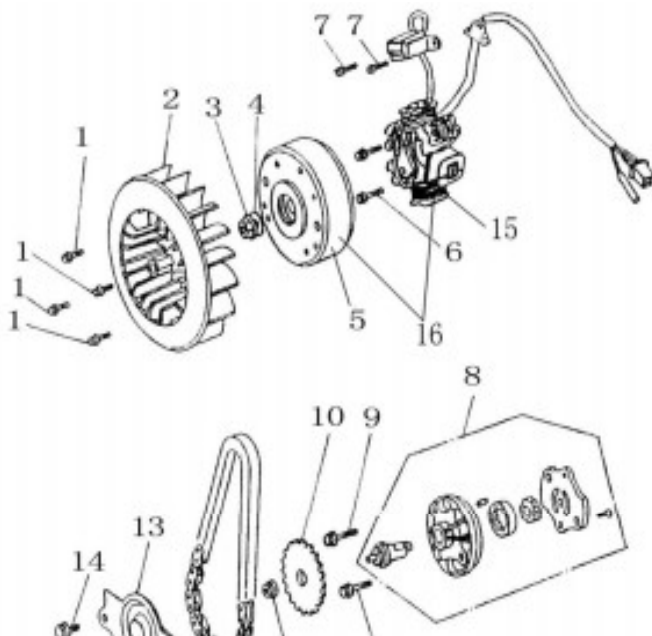



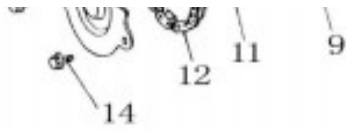

序 NO.	件 号 Code name	中文名称 Chinese	英文名称 Description	数量 Q'ty	单价 ¥	单价 \$
1	1.05.01.09.0618	六角法兰面螺栓M6×18	Hexagon Bolt M6×18	4		
2	1.20.24.01.06000	风扇组合	Fan Assy	1		
3	1.05.04.10.1213	螺母M12×1.25 H=10	Nut M6 M12×1.25 H=10	1		
4	1.05.05.04.1201	平垫12-14HV	Flat Gasket 12-14HV	1		
5	1.20.16.01.01022	飞轮（直流11级）	Rotor Assy (DC 11)	1		
6	1.05.01.09.0620	六角法兰面螺栓M6×20	Hexagon Bolt M6×20	2		
7	1.05.01.08.0512	六角螺栓M5×12	Hexagon Bolt M5×12	2		
8	1.20.14.01.03000	机油泵组合	Oil Pump Assy	1		
9	1.05.01.09.0625	螺栓M6×25	Bolt M6×25	2		
10	1.20.14.01.01000	油泵链轮	Oil Pump Sprocket Wheel	1		
11	1.05.04.02.0600	螺母M6	Nut M6	1		
12	1.20.14.01.04000	油泵链条	Oil Pump Chain	1		
13	1.20.14.01.02000	链轮端盖	Sprocket Wheel End Cap	1		
14	1.05.01.09.0612	螺栓M6×12	Bolt M6×12	2		
15	1.20.16.01.01012	定子组件（直流11级）	Stator Assy (DC 11)	1		
16	1.20.16.01.01002	磁电机总成（直流11	Magnetor Assy (DC 11)	1		

导风罩 Fan Cover Assy

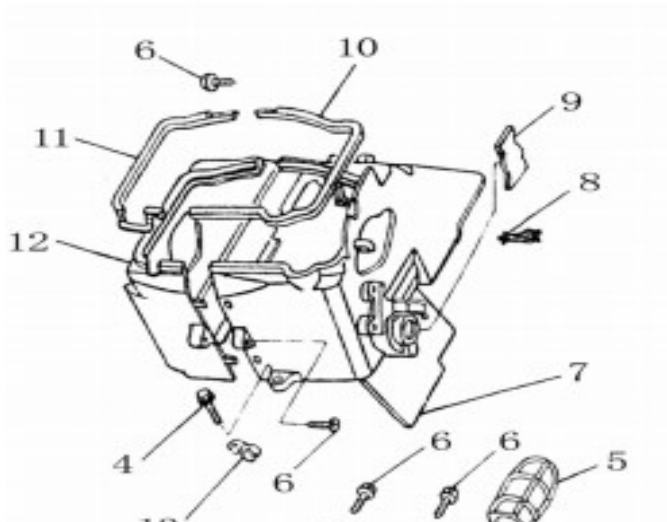



序 NO.	件号 Code name	中文名称 Chinese	英文名称 Description	数量 Q'ty	单价 ¥	单价 \$
1	1.20.24.03.03000	风扇盖	Fan cover	1		
2	1.20.24.01.03020	窗口堵盖	Blanking Cap	1		
3	1.20.24.01.04000	电缆线夹	Cable Clamp	1		
4	1.05.01.09.0625	螺栓M6×25	Bolt M6×25	3		
5	1.20.24.01.03010	冷却导管	Cooling Duct	1		
6	1.05.02.15.4816	自攻螺钉ST4.8×16-F-H	Tapping Screw ST4.8×16-F-H	5		
7	1.20.24.06.01020	161-B2上导风罩组件	Upper Fan Cover Assy	1		
8	1.20.24.01.01040	高压线夹	Cable Clamp	1		
9	1.20.24.01.01030	橡胶盖	Rubber Cover	1		
10	1.20.24.01.01010	161-B2上密封胶垫	Upper Rubber Mat	1		
11	1.20.24.01.02020	161-B2下密封胶垫	Lower Rubber Mat	1		
12	1.20.24.06.02000	161-B2下导风罩组合	Lower Fan Cover Assy	1		
13	1.20.24.01.05000	溢流管夹	Tubing Clamp	1		

车架及车架附件 Frame and Accessories



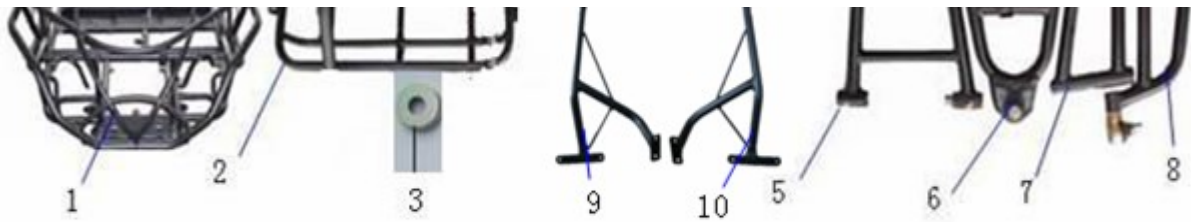

序 NO.	件号 Code name	中文名称 Chinese	英文名称 Description	数量 Q'ty	单价 ¥	单价 \$
1	0201-200GKF	车架	Frame	1		
2	02010222	后货架	Rear Carrier	1		
3	12020008	摇臂全铁防尘盖10*22*6	Iron Dust Cover M10 of Rocker	7		
4	14020160	摇臂衬套	Bush for Rocker Arm	2		
5	02010220	下摇臂组件左	Front Lower Rocker Arm(Left)	1		
6	02010221	下摇臂组件右	Front Lower Rocker Arm(Right)	1		
7	02010218	上摇臂组件左	Front Upper Rocker Arm(Left)	1		
8	02010219	上摇臂组件右	Front Upper Rocker Arm(Right)	1		
9	02010903	后泥板支架 (左)	Bracket of Rear Fender(Left)	1		
10	02010904	后泥板支架 (右)	Bracket of Rear Fender(Right)	1		
11	02010894	前泥板支架 (左)	Bracket of Front Fender(Left)	1		
12	02010895	前泥板支架 (右)	Bracket of Front Fender(Right)	1		
13	12020004	摇臂橡胶防尘盖M10	Rubber Dust Cover M10 of	20		
14	02010312	消声器支架	Muffler Bracket	1		
15	12060023	调节球头 14*1.5顺牙	Ball Joint M14×1.5	2		
16	12990002	黄油嘴	Fluid filler	6		
17	12060007	固定球头M12*1.25	Ball Joint M12×1.25	2		
18	15030017	塑料衬套 (大)	Plastic Bush (big)	12		
19	14020074	前上摇臂内套	Bush for Front Upper Rocker	2		

车架附件/消声器 Roll Bar, Muffler





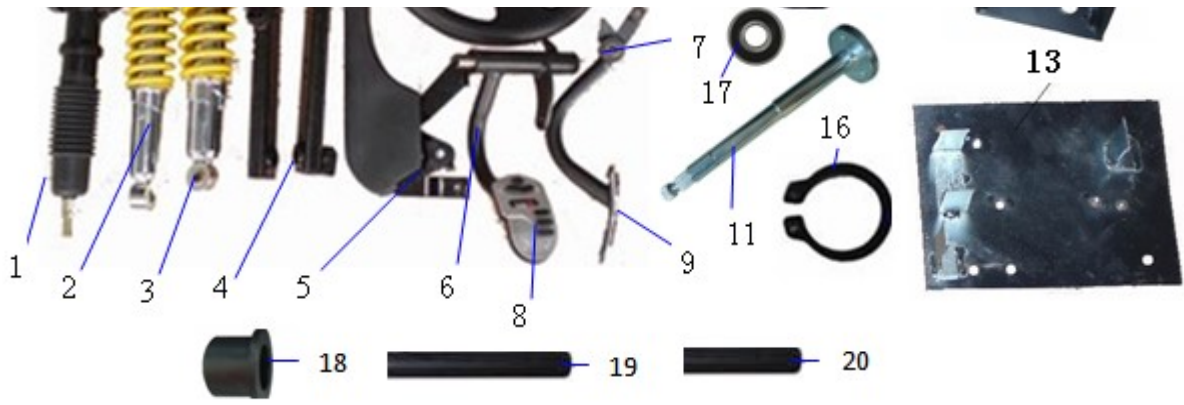

序	件号	中文名称	英文名称	数量	单价	单价
NO.	Code name	Chinese	Description	Q'ty	¥	\$
1	02030071	方向机	Redirector	1		
2	07010037	前减震	Front Shock	2		
3	07010036	后减震	Rear Shock	2		
4	05020005	坐垫滑轨	Seat Slide Rail	1		
5	04990002	手刹器 直角	Hand Brake	1		
6	02010252	刹车踏板组件	Brake Pedal	1		
7	02010244	油门踏板组件	Accelerator Pedal	1		
8	02010249	铝脚刹踏板	AL.Brake Pedal	1		
9	02010250	铝油门踏板	AL.Accelerator Pedal	1		
10	02030056	方向盘	Steering Wheel	1		
11	02030064	方向盘固定轴	Steering Wheel Stationary Shaft	1		
12	02010822	方向盘固定支架	Steering Wheel Stationary Shaft	1		
13	02010311	电器固定板组件	Fixed plate of the electrical box	1		
14	02010269	拨档器支架	Shifter Bracket	1		
15	02010331	吊架衬管	Screened Pipe	1		
16	12050003	17 轴用卡簧	Circlip 17	1		
17	12030021	轴承6903	Bearing 6903	2		
18	15030015	塑料衬套 (小)	Plastic Bush(Small)	4		
19	02020217	刹车踏板内管	Brake Pedal Inner Pipe	1		
20	02020213	油门踏板内管	Throttle Pedal Inner Pipe	1		

**后轴 Rear Axle**







序	件号	中文名称	英文名称	数量	单价	单价
NO.	Code name	Chinese	Description	Q'ty	¥	\$
1	03030231	电器盒	Electric box	1		
2	01040012	空滤器	Air Filter	1		
3	06030002	油管4.5*8.5	Oil Pipe 4.5*8.5	15cm		
4	02040159	链条530	Chain 530	52		
5	09020042	前左转向灯	Left Turning Light(F.)	1		
6	09020043	前右转向灯	Right Turning Light(F.)	1		
7	09010016	大灯	Front Light	2		
8	09050001	方反光片	Reflected Flake	2		
9	09030015	尾灯	Tail Light	1		
10	09040004	三星装饰灯	Fog Light	3		
11	09020086	后左转向灯	Left Turning Light(R.)	1		
12	09020087	后右转向灯	Right Turning Light(R.)	1		
13	01990001	二次补气装置	Twice Adding Air Instrument	1		
14	03030229	链罩	Chain Guard	1		
15	00608009	刹车灯无色灯泡	Brake Light Bulb	2		
16	00608013	转向灯灯泡(无色)	Turn Signal Light Bulb	4		
17	190098	滤芯	Filter Foam	1		
18	00608007	大灯灯泡(单爪大头)	Headlight Bulb	2		
19	02040160	530链条接头	Master Link 530	1		

电器/电缆 Electrical Components, Wires





前转角/换挡系统 Front Steering Angel, Gear Shifter

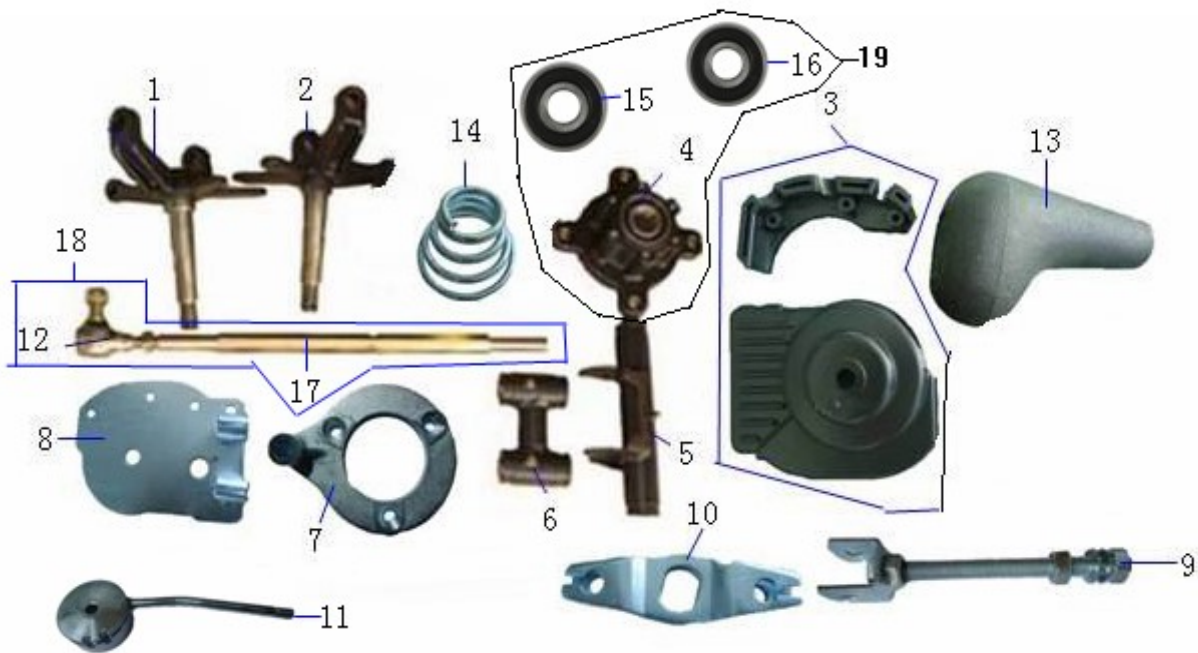

序	件号	中文名称	英文名称	数量	单价	单价
NO.	Code name	Chinese	Description	Q'ty	¥	\$
1	02030053	前转向角（左）	Front Steering Angle(L.)	1		
2	02030054	前转向角（右）	Front Steering Angle(R.)	1		
3	03030233	拨挡器塑件组合	Shifter Assy	1		
4	14010011	前轮毂座	Front Wheel Hub	2		
5	02010233	后桥托架绞链A	end bridge bracket wring A	1		
6	02010234	后桥托架绞链B	end bridge bracket wring B	1		
7	02010746	调节固定板	Adjust Dead Pate	1		
8	02010329	拨档器固定板组件	Shifter Dead Plate Assy	1		
9	02010819	调节拉杆	Control Rod	1		
10	02010749	换挡摇臂	Shift Arm	1		
11	02010842	拨档杆组件	Shift Lever	1		
12	02030055	转向拉杆（带球头-	Turning Lever(with ball)	2		
13	06990029	胶木手柄（换挡用）	Hand Shank	1		
14	07020028	拨档器扭簧	Torsional Spring	1		
15	12030023	轴承6203	Bearing 6203	2		
16	12030014	轴承6204	Bearing 6204	2		
17	14020375	转向拉杆L: 336	Steering Rod L: 336	2		
18	02030055	转向拉杆（带球头）	Turning Lever(with ball)	2		
19	02040032	前轮毂座组件	Front Wheel Hub ASSY	2		

覆盖件/线束 Body Covering, Cable



序	件号	中文名称	英文名称	数量	单价	单价
NO.	Code name	Chinese	Description	Q'ty	¥	\$
1	03010400	前泥板 (左)	Front Fender (L.)	1		
2	03010401	前泥板 (右)	Front Fender (R.)	1		
3	03050018	后装饰板	Rear Decorate Plate	1		
4	03060001	压线槽	Wire Groove	1		
5	08020070	手刹线	Hand Brake Cable	1		
6	08020069	油门线	Throttle Cable	1		
7	03060016	顶棚	Top Roof	1		
8	03990015	棚架帆布前	Front Canvas	2		
9	03990016	棚架帆布后	Rear Canvas	2		
10	06990005	棚架橡塑外套28	Rubber Sheath 28	2		
11	03990014	装饰网布	Net Cover	1		
12	03050015	仪表罩	Instrument Mask	1		
13	08020155	倒档拉线	Reverse Gear Wire	2		
14	02010256	前装饰网 (钢丝网)	Steel Mesh	1		
15	03010403	后泥板 (右)	Rear Fender (R.)	1		
16	03010402	后泥板 (左)	Rear Fender (L.)	1		
17	03050017	前装饰板	Front Decorate Plate	1		
18	02010905	仪表罩装饰网 (钢丝网)	Wire mesh for Odometer cover	1		

## 开关 Switches



序	件号	中文名称	英文名称	数量	单价	单价
NO.	Code name	Chinese	Description	Q'ty	¥	\$
1	12020002-XP	轮毂防尘盖48	Dust Cover 48	2		
2	06020082	橡胶垫6*20*3	Rubber Gasket	13		
3	190016	气门嘴	Cycle Valve	4		
4	02010253	方向机压板	Press Board	2		
5	10010002	喇叭开关	Horn Switch	1		
6	10010007	变光开关	Dimmer Switch	1		
7	10010005	转向灯开关	Switch of Turning Light	1		
8	10010006	警示灯按钮	Button of the Warning Light	1		
9	10010021	大灯开关	Switch of Head Light	1		
10	07020007	刹车开关拉簧	brake spring	2		
11	12020003-XP	轮毂防尘盖48 (ABS)	Dust Cover 48 (ABS)	4		
12	02040112	F150主动链轮	F150 Drive Sprocket	1		
13	02010828	F150主动链轮锁片	Locking Plate	1		
14	02010745	换挡拉线固定板	Dead Plate	1		
15	06020092	19孔塞	Cover 19	2		
16	02030065	万向节L:538mm	Gimbal (538mm)	1		
17	06020090	挡风玻璃橡胶垫片	Rubber gasket	4		

18	06020025	座垫橡胶	Rubber for Seat	2		

油箱/轮胎 Fuel Tank, Tires



序	件号	中文名称	英文名称	数量	单价	单价
NO.	Code name	Chinese	Description	Q'ty	¥	\$
1	06990001	二级过滤器	Second Filter	1		
2	06020013	油箱缓冲垫（带衬套）	Fuel Tank Crash Pad	4		
3	12990004	碟刹管线夹	Thread Clip	4		
4	12010007	油管夹8.5	Tubing Clamp 8.5	4		
5	09060011	后视镜	Rearview Mirror	1		
6	12010010	钢丝卡子	Clip	2		
7	05030011	油箱	Fuel Tank	1		
8	10990005	电瓶（12N9-BS）	Battery	1		
9	06010008	轮胎22*10-10	Tyre 22*10-10	2		
10	06010007	轮胎21*7-10	Tyre 21*7-10	2		
11	02040030-XP	铝轮10*8.0	Alloy Rim 10*8.0	2		
12	02040028-XP	铝轮10*5.5	Alloy Rim 10*5.5	2		
13	02040208-XP	钢圈10*5.5	Iron Rim 10*5.5	2		

14	02040209-XP	钢圈10*8.0	Iron Rim 10*8.0	2	
15	05050004	油箱盖	Fuel Tank Cap	1	
16	05050007	滤网	Filter Mesh	1	
17	10040059	油位传感器	Fuel Gauge	1	

**碟刹/坐垫 Disc Brake, Seat**

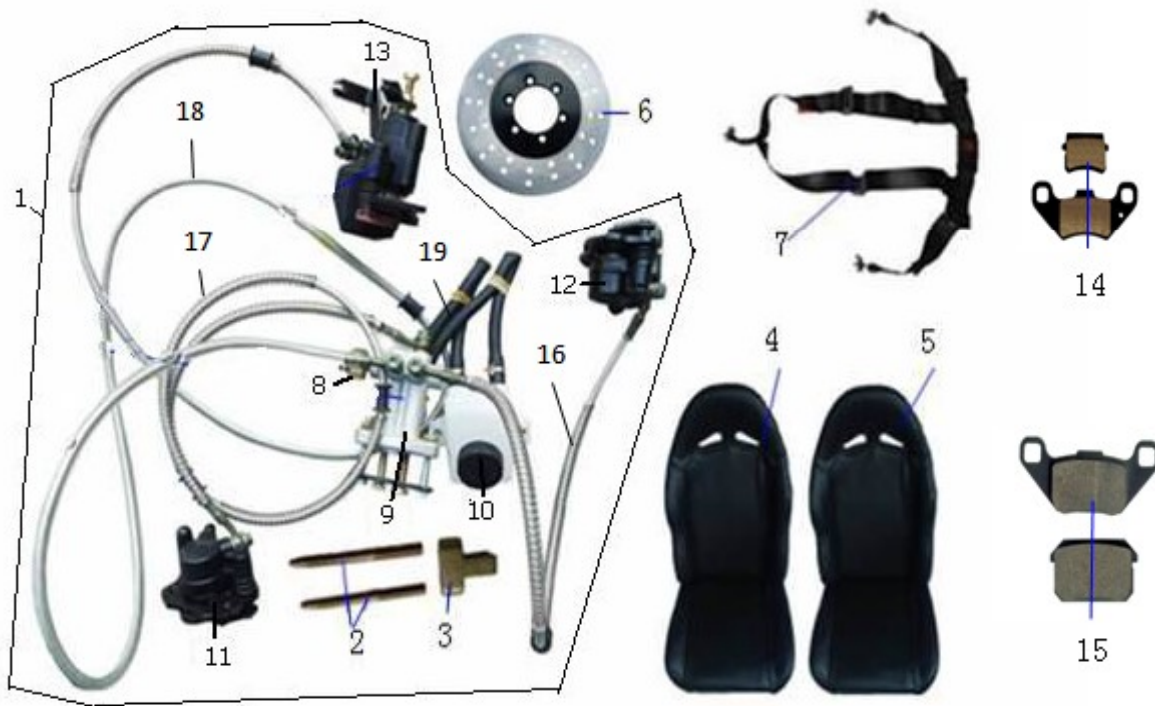

序	件号	中文名称	英文名称	数量	单价	单价
NO.	Code name	Chinese	Description	Q'ty	¥	\$
1	04010019	碟刹总成	Disc Brake Assy	1		
2	190377	推杆M8*55(带1螺母)	Brake Push Rod	2		
3	190378	推杆固定座	Push Rod Fixed Seat	1		
4	05010017	坐垫右	Seat (R.)	1		
5	05010016	坐垫左	Seat (L.)	1		
6	04020008	(前)碟刹盘 160mm	Front Brake Disc 160mm	2		
7	05020002	安全带(儿童全背)	Safety Belt	2		
8	190025	圆形液压开关	Hydraulic Switch	1		
9	190021	外挂油杯总泵	Master Cylinder	1		
10	190005	汽车泵外挂双出油壶	Oiler	1		

11	190019	圆弧AG右泵	Right Brake Caliper	1		
12	190018	圆弧AG左泵	Left Brake Caliper	1		
13	190020	05机械泵	05Rear Brake Caliper	1		
14	190009	F18A摩擦片	F18A Brake Pad	2付		
15	190010	F035摩擦片	F035 Brake Pad	1付		
16	190379	前左制动油管 760mm	Left front fluid pipe L: 760mm	1		
17	190380	前右制动油管 1080mm	Right front fluid pipe L:	1		
18	190381	后制动油管 2400mm	Rear fluid pipe L: 2400mm	1		
19	190382	输油管L:350mm	Fluid pipe L: 350mm	2		

### 随车工具 Tools Kit

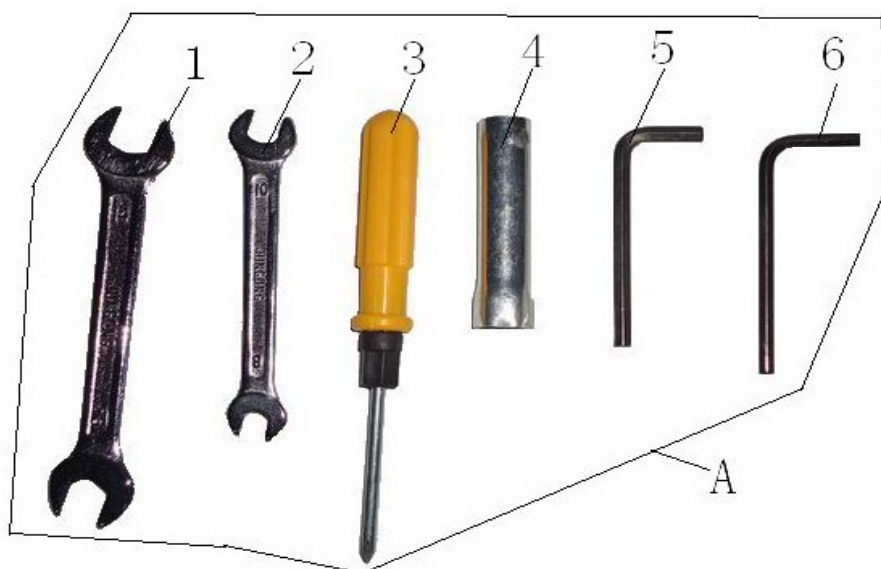

序	件号	中文名称	英文名称	数量	单价	单价
NO.	Code name	Chinese	Description	Q'ty	¥	\$
A		随车工具	Tools	1		
1	16010005	开口扳手12-14	Open Spanner(12-14)	1		
2	16010004	开口扳手8-10	Open Spanner(8-10)	1		
3	16010006	双头螺丝刀	Dual-Purpose Screwdriver	1		
4	16010007	火花塞套筒S=16	Spark Plug Box Spanner(S=16)	1		
5	16010002	内六角扳手6mm	Socket Head Screw Wrench(6mm)	1		
6	16010001	内六角扳手5mm	Socket Head Screw Wrench(5mm)	1		

2017-5-5更改涉及到后泥板左右编码，