

# DF250RTD零件目录图册

## DF250RTD PARTSLIST



### FOREWORD

When you are going to order parts you may take this booklet as reference but any differences please take the reality on vehicle as standard. To find out the name, Item

code or fitment you may check in the illustration with the size and appearance .Then with the no. in the illustration you will find out the name, item code and quantity.

There will no notice to you ahead of any change of the information in this booklet.

## 发动机组件 Engine ASSY

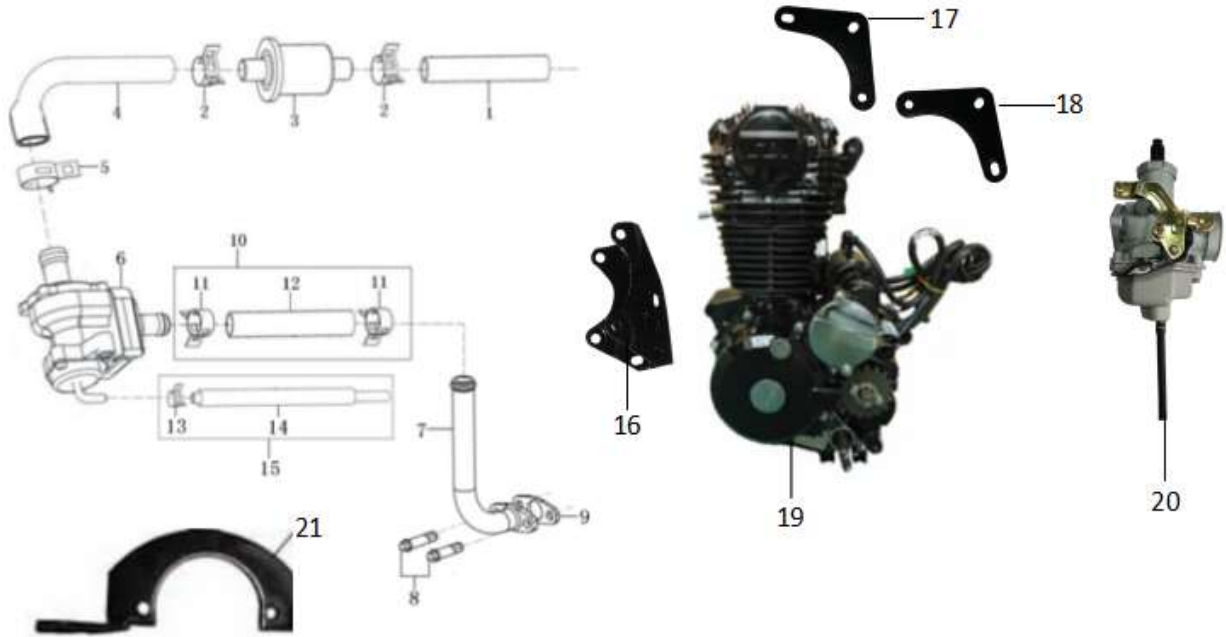

序 NO	件号 Item Code	中文名称 Chinese	英文名称 Description	数量		单价	
				Q'ty	¥	\$	
1	16156-I008-0100	CG125D二次空滤器连接胶管 II (14×9×100)	Connecting Pipe	1			
2	16157-I008-0000	二次空滤器连接胶管卡圈14	Hoop	2			
3	16160-I008-0000	CG125D二次空滤器部件	Second Air Box Valve	1			
4	16156-I008-0000	CG125D二次空滤器连接胶管 I (14×9×90(95))	Connection Pipe	1			
5	16157-I008-0100	二次空滤器连接胶管卡圈15.3	Hoop	1			
6	18090-J034-0001	CG150D空气泵(带防尘胶套)	Gas Pump	1			
7	1809B-LA66-00000Y	CG200-A废气循环铁管组合	Iron Pipe	1			
8	B166740A06001670X	GB16674小盘螺栓M6×16	Bolt M6X16	2			
9	90268-DA80-0000	PW70废气循环铁管纸垫	Paper Gasket	1			
10	18110-LA66-0000	CG200-A废气循环橡胶管组件 I	Rubber Pipe	1			
11	18097-I008-0000	CG125D废气循环管 I 卡箍	Clamp	2			
12	18092-LA66-0000	CG200-A废气循环橡胶管 I (900)	Rubber Pipe	1			
13	18097-I008-0100	CG125D废气循环管 II 卡箍	Clamp	1			
14	18092-I008-0103	废气循环橡胶管 II-4#	Rubber Pipe	1			
15	18110-I008-0103	废气循环橡胶管组件 II-4#	Rubber Pipe	1			
16	02011851	发动机(前)下固定板		1			
17	02011850-2	发动机上固定板右		1			

18	02011850	发动机上固定板左		1		
19	01010076	发动机		1		
20	01030023	化油器		1		
21	02010351	二次补气阀固定片	fixed pieces for air valve	1		

### 气缸头部件/气缸体部件Cylinder Head ASSY/Cylinder ASSY

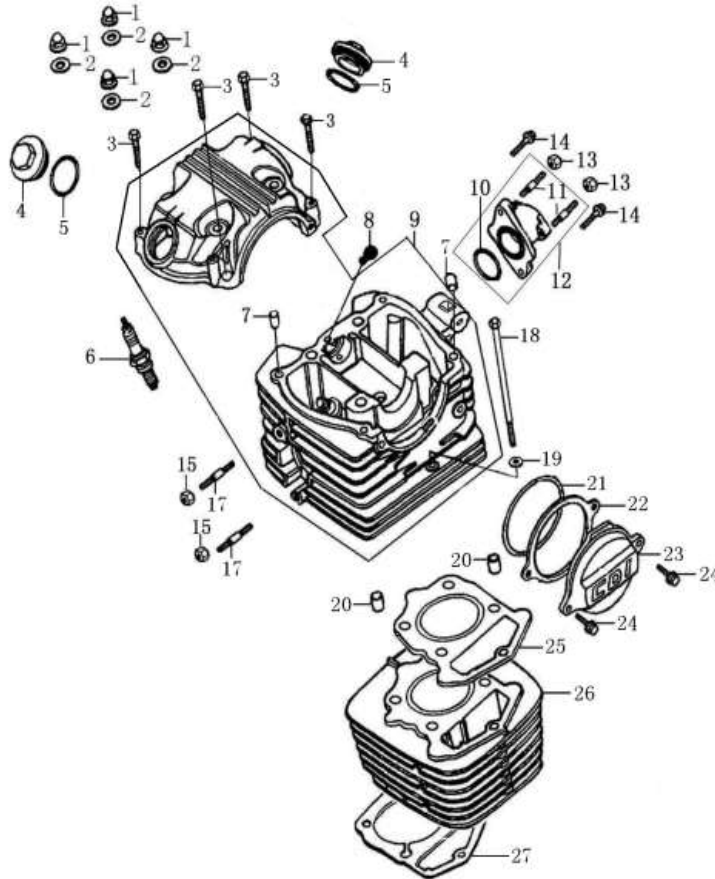

序 NO	件号 Item Code	中文名称 Chinese	英文名称 Description	数量 Q' ty	单价	
					¥	\$
1	91201-I006-00000X	CB125脚缸头盖盖形螺母M8(白铬)	Cap Nut M8	4		
2	93301-80852018000	CB125盖形螺母铜垫圈8.5×2×18	Cap Nut Copper Washer 8.5×2×18	4		
3	B166740A06003570X	GB16674小盘螺栓M6×35(兰白锌)	Bolt M6×35	4		
4	11230-I006-00000G	CB125脚气门室盖(6806)	Cover, Valve Chamber	2		
5	90101-20350000300	CB125气门盖O形圈35×3(氟硅胶)	Valve Cover O-ring 35×3	2		
6	81300-I006-0000	CB125脚火花塞部件(CB125脚)	Spark Plug	1		
7	91521-08001400000	70定位销8×14×6.3	Pin 8×14×6.3	2		
8	11015-I006-0000	CB125脚橡胶油塞	Casing Cap	1		
9	1122B-ME05-000086	CB250D-G气缸头组合(环保II代 6806)M8/58	Cylinder Head Assy	1		
10	90101-20335000300	CB125进气管O形圈33.5×3(氟硅胶)	Inlet Pipe O-ring 33.5×3	1		
11	91127-I006-0000	CB125脚进气管双头螺栓(普通 L:27mm)	Inlet Pipe Stud Bolt	2		
12	15800-L044-0041	CB200进气管组合(JQ-9XHB)	Inlet Pipe Assy	1		
13	B061700006000090X	GB6170螺母M6(兰白锌)	Nut M6	2		

14	B057830006002070X	GB5783螺栓M6×20(兰白锌)	Bolt M6×20	2		
15	B061700008000090X	GB6170螺母M8(兰白锌)	Nut M8	2		
17	91138-I008-01000X	CG125D缸头排气口双头螺栓M8×38(兰白锌)	Stud Bolt M8×38	2		
18	B166740A06012570X	GB16674小盘螺栓M6×125(兰白锌)	Bolt M6×125	1		
19	93301-3062201300B	70缸头盖铁垫圈6.2×2×13(白锌)	Washer 6.2×2×13	1		
20	91521-10002000000	CG125脚定位销10×20	Pin 10×20	2		
21	90101-20750000265	CB125气缸头左盖O形圈75×2.65(氟硅胶)	Cylinder Head O-ring 75×2.65	1		
22	90202-I006-0000	CB125脚气缸头左盖密封垫	Cylinder Head Gasket	1		
23	11227-I006-100186	CB125脚气缸头左盖(老款)CDI 6806	Left Cover of Cylinder Head	1		
24	B166740A06002070X	GB16674小盘螺栓M6×20(兰白锌)	Bolt M6×20	2		
25	9022B-ME05-0000	CB250D-G气缸头密封垫组合(金属)	Cylinder Head Gasket Assy	1		
26	1110B-ME05-000086	CB250D-G气缸体部件(缸标250 6806)	Cylinder Block Assy	1		
27	90205-J025-0000	CB150D气缸体密封垫	Cylinder Block Gasket Assy	1		

### 配气机构Camshaft & Valves

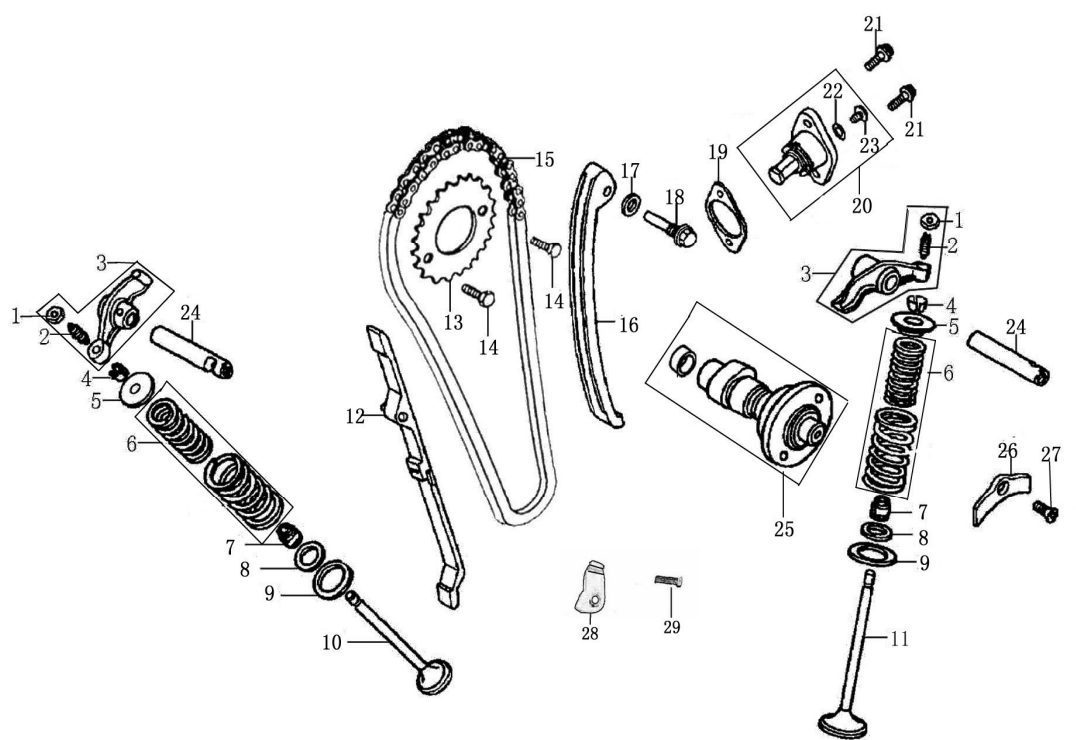

序 NO	件号 Item Code	中文名称 Chinese	英文名称 Description	数量 Q'ty	单价	
					¥	\$
1	15403-I006-0000	CB125脚气门间隙调节螺母	Nut, valve Clearance	2		
2	15404-I006-0000	CB125脚气门间隙调节螺钉	Screw, Valve Clearance	2		
3	1540A-I006-0000	CB125脚气门摇臂组合	Rocker Arm ASSY, valve	2		
4	15707-I006-0000	CB125脚气门锁夹	Valve Locker	4		
5	15705-I006-0000	CB125脚气门弹簧座(上)	Spring Seat(upper)	2		
6	15710-I006-0000	CB125脚气门内外弹簧组合	Inner Out Spring Assy	2		
7	1572B-I008-0000	CG125D挡油罩组合	Seal, Valve Stem	2		
8	15708-I008-0000	CG125D气门内弹簧座圈(下)	Spring Seat(lower)	2		
9	15706-I008-0000	CG125D气门外弹簧座圈(下)	Spring Seat(lower)	2		
10	15702-LA74-0000	CB200-C排气门(堆焊合金)	Exhaust Valve	1		
11	15701-LA74-0000	CB200-C进气门	Intake Valve	1		

12	1553A-ME05-0000	CB250D-G链条导向板组合	Chain Guide Plate	1		
13	15301-L044-0000	CB200正时从动链轮(34)	Timing Driven Sprocket	1		
14	B057830006001270B	GB5783螺栓M6×12(白锌)	Bolt M6×12(white zinc)	2		
15	1532B-ME05-0000	CB250D-G正时链条组合(7×104 齿形链)	Sprocket Chain	1		
16	1552A-ME05-0000	CB250D-G链条张紧板组合	Tension Plate ASSY	1		
17	93301-70851514000	70导向销轴铝垫圈8.5×1.5×14	Washer 8.5×1.5×14	1		
18	91109-I006-00000X	CB125脚张紧条芯轴螺栓(白铬)	Tensioner Axle Bolt	1		
19	90211-I049-0000	CB125D张紧器密封垫	Tensioner Gasket	1		
20	1554B-I049-000086	CB125D张紧器组合(6806)	Tensioner Assy	1		
21	B000700106001670X	GB70.1螺钉M6×16(兰白锌)	Bolt M6×16	2		
22	90101-20090000180	CB125张紧器O形圈9×1.8(氟硅胶)	Tensioner O-ring 9×1.8	1		
23	91120-I006-0000	CB125脚张紧调节螺栓M6×10	Tensioner Bolt M6×10	1		
24	15402-I006-0100	CB125脚-2#气门摇臂轴(PDK专用)	Rocker Shaft	2		
25	15100-ME05-0003	CB250D-G凸轮轴部件(TPI轴承)	CB250D-G Cam Shaft Assy	1		
26	11201-I006-0000	CB125脚气门摇臂轴定位板	Rocker Arm Positioning Plate	1		
27	B008190106001620B	GB819.1螺钉M6×16(白锌)	Screw M6×16	1		
28	2143B-L044-0000	CB200链条护板组合	Chain Protect Plate Assy	1		
29	B166740006001670B	GB16674大盘螺栓M6×16(白锌)	Bolt M6×16	1		

### 曲轴箱盖 Crankcase Cover 1

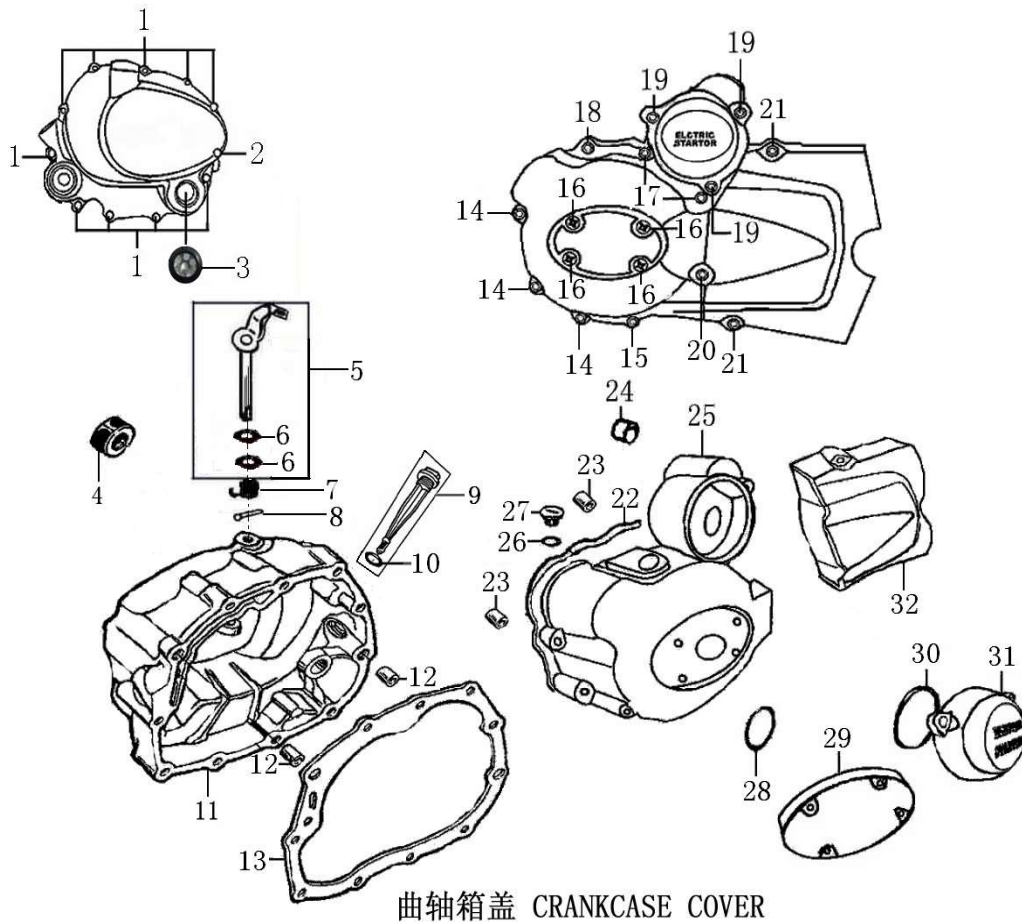

序 NO	件号 Item Code	中文名称 Chinese	英文名称 Description	数量 Q'ty	单价 ¥	单价 \$
1	B166740A06004070X	GB16674小盘螺栓M6×40(兰白锌)	Bolt M6×40	10		
2	B166740A06005070X	GB16674小盘螺栓M6×50(兰白锌)	Bolt M6×50	1		
3	12426-I008-0000	CG125D机油观察窗	Oil Lelve Sight Window	1		

4	90304-I006-0000	CB125脚启动轴油封16×28×7(丁腈胶)	Oil Seal16×28×7	1	
5	2242A-IA18-01000F	PZ125离合器操纵臂组合	Controlling Arm ASSY,Clutch	1	
6	90101-30087000190	CB125脚操纵臂O形圈8.7×1.9(氟橡胶)	O-ring 8.7×1.9	2	
7	22427-I006-0000	CB125脚离合器操纵臂弹簧	Clutch Controlling Arm Spring	1	
8	B0087901030120000	GB879.1销 3×12	Pin 3×12	1	
9	14301-I006-01000G	CB125脚机油尺组合(白板 镀铬)分体式	Oil Gauge ASSY	1	
10	90101-10180000300	CG125机油尺O形圈18×3(丁腈胶)	Oil Gauge O-ring 18×3	1	
11	12421-I008-660063	CG125D右曲轴箱盖[白板(超风款)6805]电感式	Cover COMP. Right Crankcase	1	
12	91521-08001400000	70定位销8×14×6.3	Pin 8×14×6.3	2	
13	90206-I008-0000	CG125D右曲轴箱盖密封垫	Gasket, R.Crankcase Cover	1	
14	B166740A06002570X	GB16674小盘螺栓M6×25(兰白锌)	Bolt M6×25(blue white zinc)	3	
15	B166740A06003570X	GB16674小盘螺栓M6×35(兰白锌)	Bolt M6×35(blue white zinc)	1	
16	B008180006001220X	GB818螺钉M6×12(兰白锌)	Bolt M6×12(blue white zinc)	4	
17	B166740A06005570X	GB16674小盘螺栓M6×55(兰白锌)	Bolt M6×55(blue white zinc)	2	
18	B166740A06003570X	GB16674小盘螺栓M6×35(兰白锌)	Bolt M6×35(blue white zinc)	1	
19	B166740A06002070X	GB16674小盘螺栓M6×20(兰白锌)	Bolt M6×20(blue white zinc)	3	
20	B166740A06006070X	GB16674小盘螺栓M6×60(兰白锌)	Bolt M6×60(blue white zinc)	1	
21	B166740A06002870X	GB16674小盘螺栓M6×28(兰白锌)	Bolt M6×28(blue white zinc)	2	
22	90204-I049-0000	CB125D左曲轴箱前盖密封垫	Gasket, L.crankcase Cover	1	
23	91521-08001400000	70定位销8×14×6.3	Pin 8×14×6.3	2	
24	92102-I008-0001	CG125D含油轴承(铁基)	Oil Bearing	1	

### 曲轴箱盖 Crankcase Cover 2

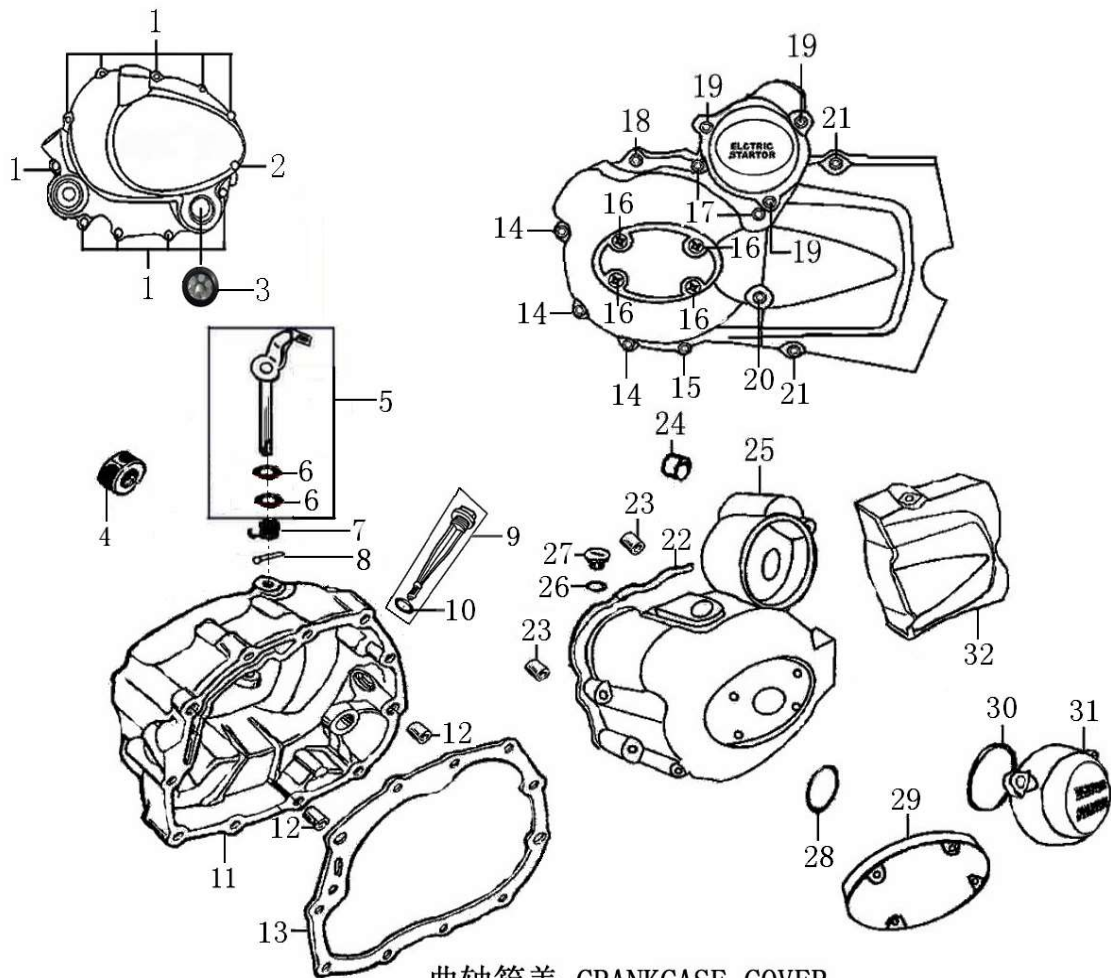

序号 NO	件号 Item Code	中文名称 Chinese	英文名称 Description	数量 Q'ty	单价 ¥ \$	
25	12301-I049-000063	CB125D左曲轴箱前盖[白板(普通款) 6805]	Front part, L.Crankcase Cover	1		
26	90101-10132000265	C100小视孔盖O形圈13.2×2.65(丁腈胶)	Manhead O-ring 13.2×2.65	1		
27	12303-G011-00000G	C100小视孔盖(白铬)	Cap, Small View Hole	1		
28	90101-10274000265	C100大视孔盖O形圈27.4×2.65(丁腈胶)	O-ring 27.4×2.65	1		
29	12307-I008-10010G	CG125D左前盖装饰盖(ZONGSHEN 鲸鱼款 白铬)	Decoratecover L.Crankcase Cover	1		
30	90101-10630000265	CB125D双联盖O形圈63×2.65(丁腈胶)	O-ring 63×2.65	1		
31	12308-I049-01000G	CB125D双联齿轮盖[白板(老款) 白铬]	Cover,Reduction Gear	1		
32	12302-I049-430063	CB125D左曲轴箱后盖[(CB125D-PT-13#) 6805]	Rear Part,L.Crankcase Cover	1		

### 离合器总成 Clutch ASSY

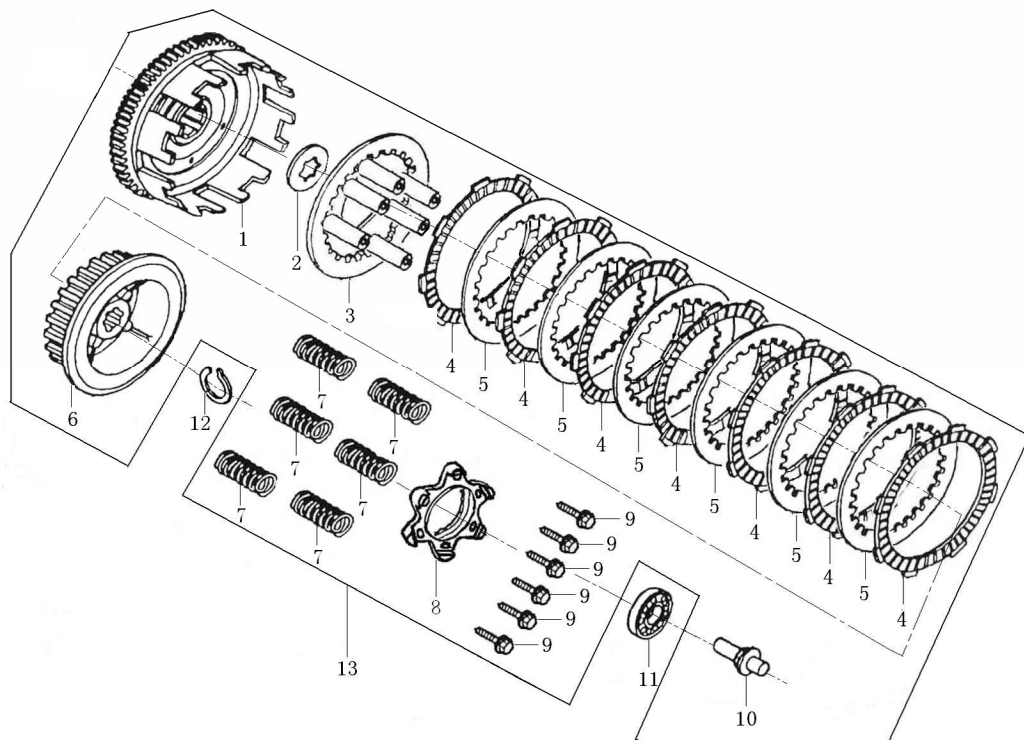

离合器  
CLUTCH

序 NO	件号 Item Code	中文名称 Chinese	英文名称 Description	数量 Q'ty	单价	
					¥	\$
1	22150-LA73-0100	CG200-A水冷-3#离合器外罩组合	Out Case Cover, Clutch	1		
2	22002-I006-0000	CB125脚离合器花键垫圈	Washer For Spline	1		
3	22122-LA73-0000	CG200-A水冷离合器压盘	Pressure Board,Clutch	1		
4	22214-LA73-0000	CG200-A水冷离合器主动摩擦片	Drive Friction Dics	7		
5	22215-J034-0000	CG150D离合器从动摩擦片(六柱)	Outer Friction Dic A	6		
6	22105-LA73-0100	CG200-A水冷-3#离合器中心套	Central Sleeve,Clutch	1		
7	22142-LA73-0000	CG200-A水冷离合器弹簧	Clutch Spring	6		
8	22121-LA12-0000	CG200D-B离合器端盖	Cluct End Cover	1		
9	91129-J034-00000B	CG150D离合器法兰盘螺栓M5×20(白锌)	Bolt M5×20	6		
10	22403-I006-0000	CB125脚离合器推杆	Pushing Rod,Clucth	1		
11	92102-00000016003	轴承(16003)	Bearing (16003)	1		
12	91403-I008-0000	CG125D离合器挡圈20	Elastci Check Ring	1		
13	22000-LA73-0903	CG200-A水冷-3#离合器总成	Clutch Assy(Without Bearing)	1		

机油泵部件/机油滤清器部件 Oil Pump/ Oil Filter

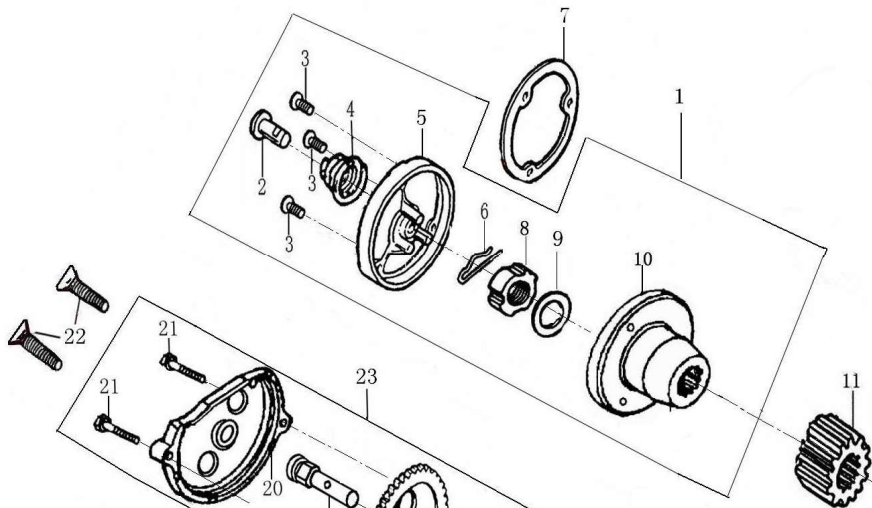



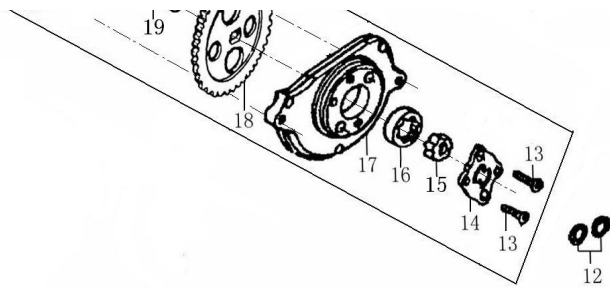

序 NO	件号	中文名称	英文名称	数量	单价	
	Item Code	Chinese	Description	Q' ty	¥	\$
1	14200-IA20-0100	SB125-2#机油滤清器部件	Oil Filter	1		
2	14201-I006-0000	CB125脚机油滤清器出油管	Oil Pipe	1		
3	B008190105001220B	GB819.1螺钉M5×12(白锌)	Screw M5×12	3		
4	14202-I006-0000	CB125脚机油滤清器出油管弹簧	Spring of Oil Pipe	1		
5	14207-IA20-00000W	SB125机油滤清器盖(抛丸钝化)	Oli Filter Cover	1		
6	14208-I006-0000	CB125脚机油滤清器开口销	Oli Filter Pin	1		
7	90209-IA20-0000	SB125滤清器端盖密封垫	Gasket ,Oil Filter	1		
8	91203-IA20-0000	SB125机油滤清器螺母	Oli Filter Nut	1		
9	22004-I006-0000	CB125脚离合器碟形垫圈16.5×2×27	Dish Washer,Clutch	1		
10	14203-IA20-0100	SB125-2#机油滤清器转子组件	Rotor Assy.of Oil Filter	1		
11	23101-I006-0000	CB125脚主动齿	Primary Drive Gear	1		
12	90101-10094000240	CG125机油泵O形圈9.4×2.4(丁腈胶)	O-ring 9.4×2.4	2		
13	B008190104001020B	GB819.1螺钉M4×10(白锌)	Screw M4×10	2		
14	14108-L044-0200	CB200机油泵盖板(电感式 钢齿)	Oil Pump Cover	1		
15	14111-L044-0200	CB200机油泵内转子(电感式 钢齿)	Inner Rotor, Oil Pump	1		
16	14112-L044-0000	CB200机油泵外转子	Outer Rotor, Oil Pump	1		
17	14110-L044-0200	CB200机油泵体(电感式 钢齿)	Oil Pump Body	1		
18	14102-L044-0001	CB200机油泵齿轮(m=1.75 z=37 电感式 钢齿)	Gear,Oil Pump	1		
19	14107-L044-0200	CB200机油泵油泵轴(电感式 钢齿)	Shaft, Oil Pump	1		
20	14113-L044-0000	CB200机油泵齿轮盖(电感式 钢齿)	Gear Cover, Oil Pump	1		
21	B057820005002070B	GB5782螺栓M5×20(白锌)	Bolt M5×20	2		
22	B008190106003020B	GB819.1螺钉M6×30(白锌)	Screw M6×30	2		
23	14100-L044-0000	CB200机油泵部件(37齿 电感式)	Oil Pump Assy	1		

曲轴箱 Crankcase 1

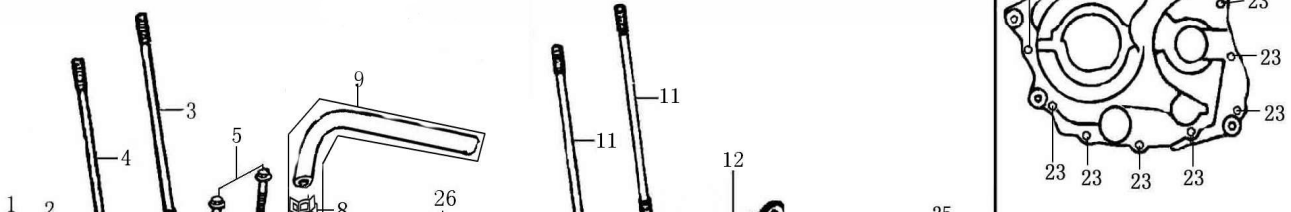

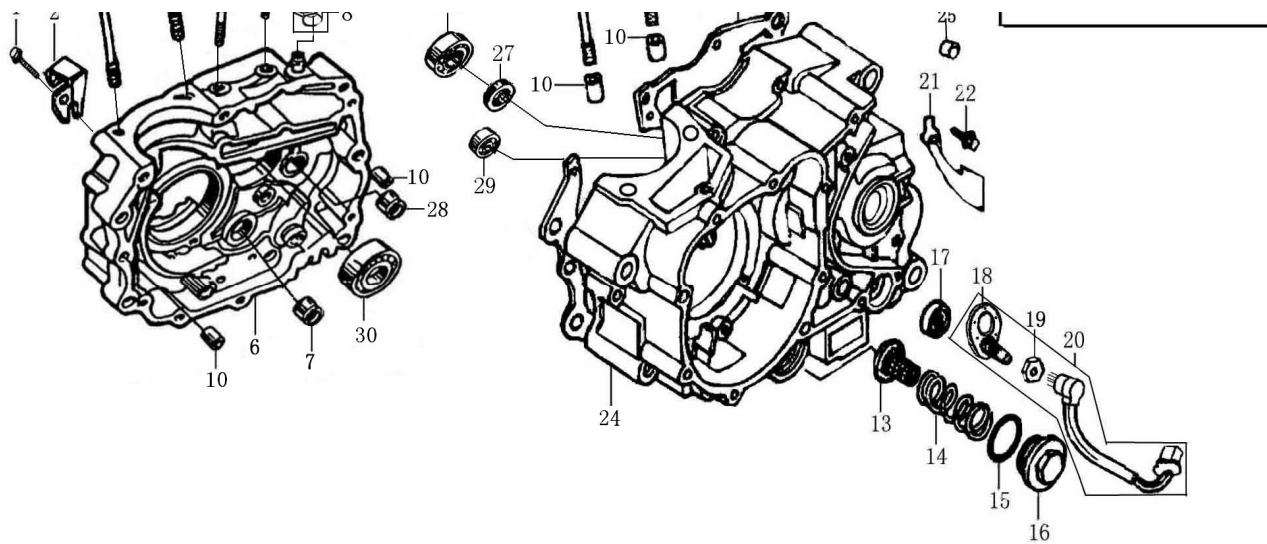

序 NO	件号 Item Code	中文名称 Chinese	英文名称 Description	数量		单价	
				Q'ty	¥	\$	
1	B166740A06005570X	GB16674小盘螺栓M6×55(兰白锌)	Bolt M6×55	1			
2	22422-IA18-01000G	PZ125-2#离合器钢索支架(白铬)	Clutch Cable Holder	1			
3	91102-L044-0000	CB200气缸双头螺栓B(229mm)	Cylinder Stud Bolt B	1			
4	91102-L044-0100	CB200-2#气缸双头螺栓B(229mm)	Cylinder Stud Bolt B	1			
5	B166740A06002870X	GB16674小盘螺栓M6×28(兰白锌)	Bolt M6×28	2			
6	1222B-ME05-010063	CB250D-G右曲轴箱组合(低噪音专用 6805)	Right Crankcase Assy	1			
7	92102-000HK212810	滚针轴承(HK21×28×10)	Bearing (HK212810)	1			
8	18097-I008-0000	CG125D废气循环管 I 卡箍	Clamp	3			
9	12130-MA95-0200	CG250-3#通气管组件(复合层材料 卡箍2个)	Pipe ASSY	1			
10	91521-10001400000	CG125脚定位销10×14	Pin 10×14	4			
11	91101-KA35-0000	IB175-FC气缸双头螺栓A(240mm)	Cylinder Stud Bolt A(240mm)	2			
12	90208-ME05-0000	CB250D-G曲轴箱密封垫	Crankcase Gasket	1			
13	1431B-I006-0000	CB125脚机油过滤网组合	Oil Filter Strainer	1			
14	14221-I006-0000	CB125脚机油过滤网弹簧	Spring of Oil Filter Strainer	1			
15	90101-20350000300	CB125气门盖O形圈35×3(氟硅胶)	O-ring 35×3	1			
16	11230-I006-00000W	CB125脚气门室盖(抛丸钝化)	Cover, Valve Chamber	1			
17	90301-I006-0000	CB125脚换档臂油封14×28×7(丁腈胶)	Oil Seal 14×28×7	1			
18	88001-I049-0500	CB125D档显板(五档国际档)	Gearshift Switch plate	1			
19	91204-I049-0000	CB125D档显板螺母M10	Nut M10	1			
20	8803B-I049-050055	CB125D档显线束组合(五档国际 L:550)接口D01	Gearshift Switch Lamp	1			
21	12103-I008-0000	CG125D挡线片	Positioning Plate	1			
22	B166740A06001270B	GB16674小盘螺栓M6×12(白锌)	Bolt M6×12	1			
23	B166740A06005070X	GB16674小盘螺栓M6×50(兰白锌)	Bolt M6×50	10			
24	1212B-IA27-000063	CB133左曲轴箱组合(6805)	Left Crankcase Assy	1			

曲轴箱 Crankcase 2

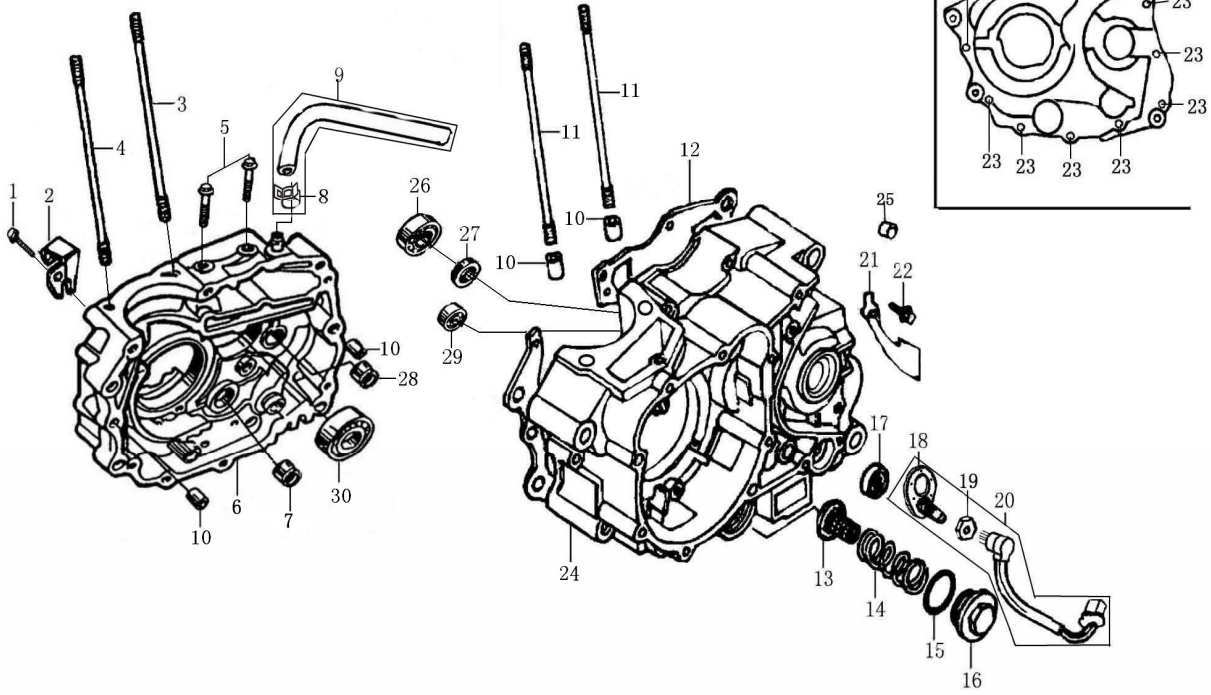

序 NO	件号 Item Code	中文名称 Chinese	英文名称 Description	数量 Q' ty	单价 ¥ \$	
25	92102-I008-0001	CG125D含油轴承(铁基)	Bearing	1		
26	92102-00000006204	轴承(6204)	Bearing (6204)	1		
27	90303-I006-0000	CB125脚副轴油封20×34×7(丁腈胶)	Oil Seal 20×34×7	1		
28	92102-000NK152312	滚针轴承(NK15×23×12)	Bearing (NK15×23×12)	1		
29	92102-0000TM6202Z	轴承(TM6202Z)	BearingG (TM6202Z)	1		
30	92102-00000006006	轴承(6006)	Bearing (6006)	1		

曲轴连杆部件/活塞 Crankcase Connecting Rod ASSY/Piston

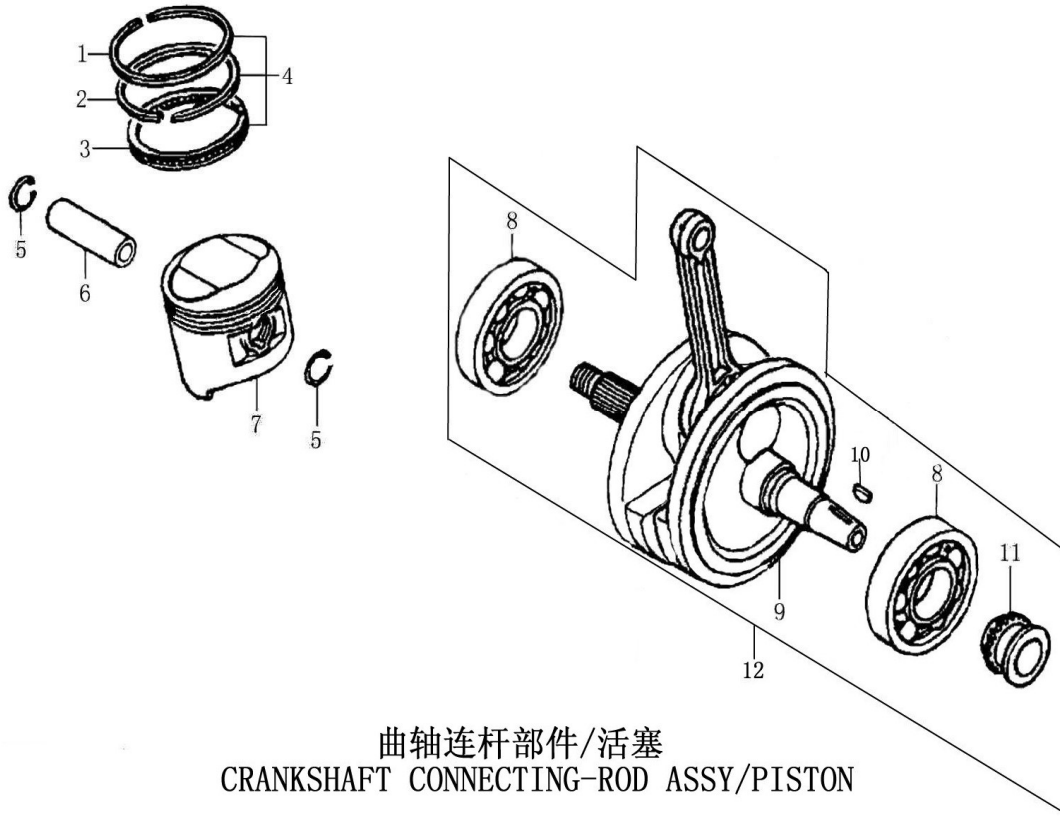

曲轴连杆部件/活塞  
CRANKSHAFT CONNECTING-ROD ASSY/PISTON

序 NO	件号	中文名称	英文名称	数量 Q'ty	单价	
	Item Code	Chinese	Description		¥	\$
1	13103-ME05-0000	CB250D-G活塞环一	Piston Ring 1	1		
2	13104-ME05-0000	CB250D-G活塞环二	Piston Ring 1	1		
3	13120-ME05-0000	CB250D-G油环组合	Oil Ring ASSY	1		
4	1310A-ME05-0100	CB250D-G活塞环总成	Pistonring ASSY	1		
5	91401-I006-0000	CB125脚活塞销挡圈	Check, Piston Pin	2		
6	13102-LA66-0000	CG200-A活塞销	Pin Piston	1		
7	13101-LE26-0000	CBB200活塞	Piston	1		
8	92102-00TMSC06B42	左曲柄轴承(TM-SC06B42)	Bearing (TM-SC06B42)	2		
9	13220-ME05-0000	CB250D-G曲轴连杆组合	Connection Rod Comp 3	1		
10	91601-I008-0000	CG125D半圆键25×14×4	Woodruff Key	1		
11	13222-ME05-0000	CB250D-G正时主动链轮	Drive Sprocket	1		
12	1320B-ME05-0000	CB250D-G曲轴连杆部件	Crankshaft Connection Rod Assy	1		

## 传动机构 Transmission Mechanism 1

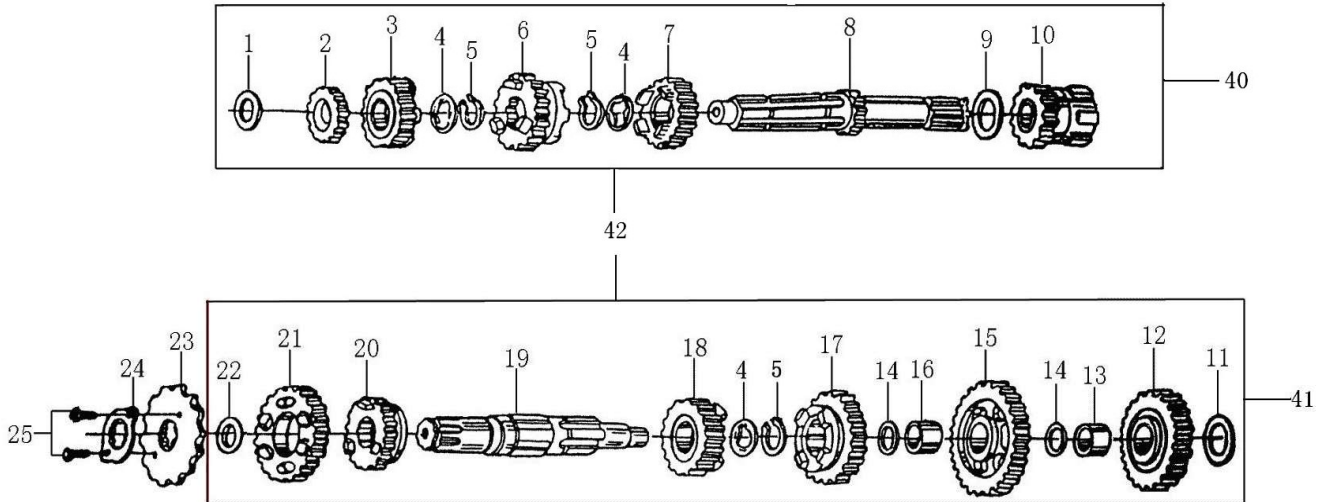

序 NO	件号 Item Code	中文名称 Chinese	英文名称 Description	数量 Q'ty	单价	
					¥	\$
1	93301-61521025000	CB125主轴止推垫圈 15.2×1×25	Washer 15.2×1×25	1		
2	23222-LA73-0002	CG200-A水冷主轴2档齿轮	Gear M-2	1		
3	23222-LA73-0005	CG200-A水冷主轴5档齿轮	Gear M-5	1		
4	23223-I006-0000	CB125脚齿轮隔圈 17.3(20)×1.6×26	Washer 17.3(20)×1.6×26	3		
5	91402-D002-0100	70启动轴挡圈 φ18.5×1.2×φ22.1	Start Axle Check Ring φ18.5×1.2×φ22.1	3		
6	23222-LA73-0004	CG200-A水冷主轴4档齿轮	Gear M-4	1		
7	23222-LA73-0003	CG200-A水冷主轴3档齿轮	Gear M-3	1		
8	23221-LA73-0000	CG200-A水冷主轴芯轴	Transmission Main Shaft	1		
9	93301-62020527000	CB125主轴止推垫圈 20.2×0.5×27	Washer 20.2×0.5×27	1		
10	23231-I008-0000	CG125D主轴起动齿轮组合	Final Shaft	1		
11	93301-61521030000	CB125副轴止推垫圈 15.2×1×30	Washer 15.2×1×30	1		
12	23248-I008-0000	CG125D副轴启动过桥齿轮	Gear	1		
13	23203-I008-0003	CG125D副轴启动齿轮衬套	Gear Bush	1		
14	93301-51650524000	CG125D副轴止推垫圈 16.5×0.5×24	Washer 16.5×0.5×24	2		
15	23242-LA73-0001	CG200-A水冷副轴1档齿轮	Gear C-1	1		
16	23203-I006-0001	CB125脚副轴1档齿轮衬套	Gear Bush	1		
17	23242-LA73-0003	CG200-A水冷副轴3档齿轮	Gear C-3	1		
18	23242-LA73-0004	CG200-A水冷副轴4档齿轮	Gear C-4	1		

19	23241-I008-0000	CG125D-1#五档副轴芯轴	Transmission Counter Shaft	1	
20	23242-LA73-0005	CG200-A水冷副轴5档齿轮	Gear C-5	1	
21	23242-LA73-0002	CG200-A水冷副轴2档齿轮	Gear C-2	1	
22	93301-52001027000	CG125D副轴止推垫圈 20×1×27	Washer 20×1×27	1	
23	23401-MA95-0001	CG250主动链轮(520.13)	Drive Sprocket(520.13)	1	
24	23402-I006-0000	CB125脚主动链轮固定板	Fixing Plate, Drive Sprocket	1	

### 传动机构 Transmission Mechanism 2

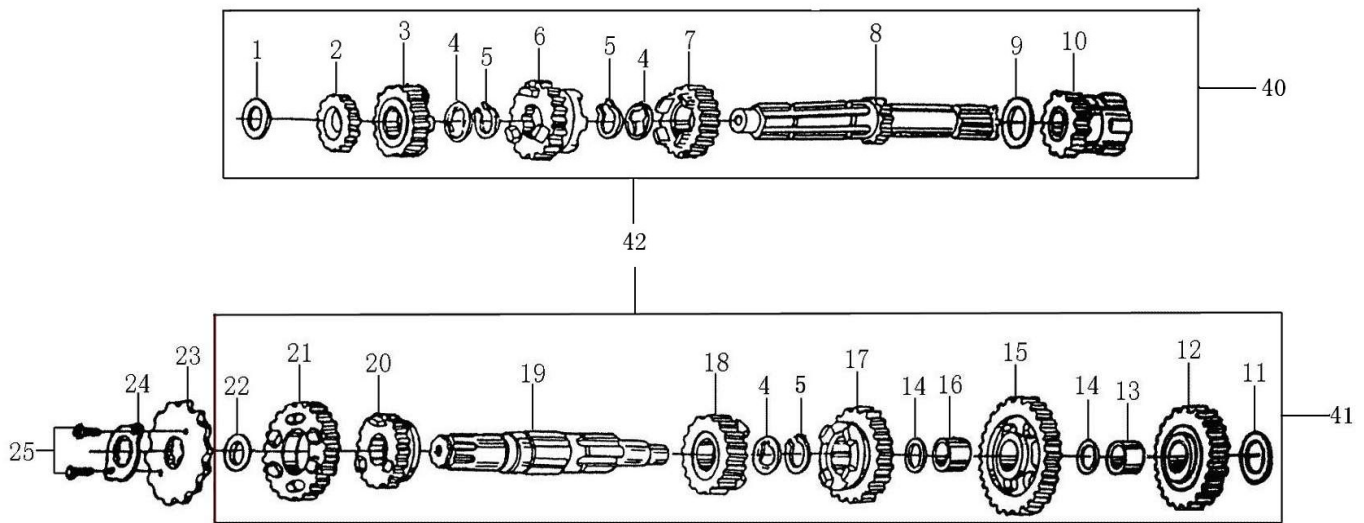

序 NO	件号	中文名称	英文名称	数量	单价	
	Item Code	Chinese	Description	Q'ty	¥	\$
25	B057830006001070B	GB5783螺栓M6×10(白锌)	Bolt M6×10	2		
26						
27						
28						
29						
30						
31						
32						
33						
34						
35						
36						
37						
38						

39					
40	23220-LA73-0000	CG200-A水冷主轴组合	Tansmmison Main Shaft	1	
41	23240-LA73-0000	CG200-A水冷-1#副轴组合	Transmmison Counter Shaft	1	
42	23200-LA73-0200	CG200-A水冷-2#主副轴组合	Tansmmison Shaft ASSY	1	

变速机构 Gearshift Mechanism

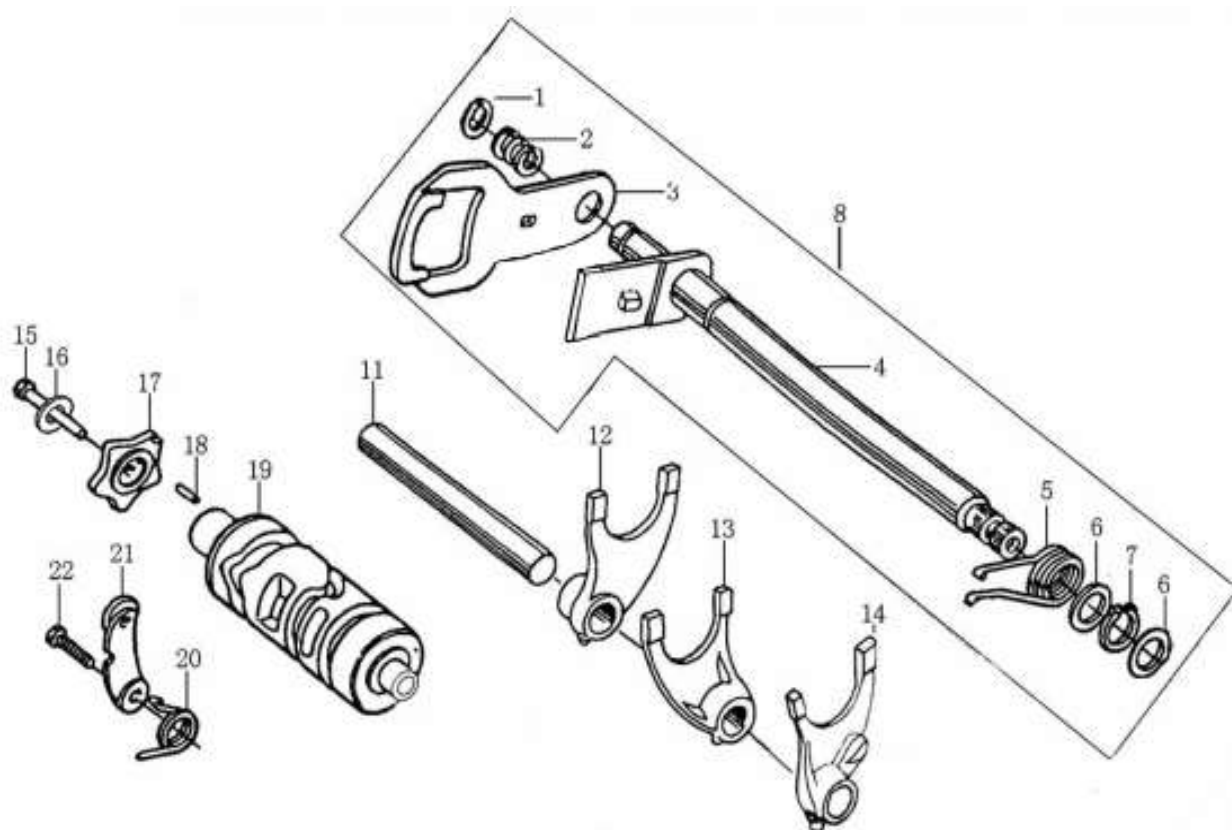

序 NO	件号 Item Code	中文名称 Chinese	英文名称 Description	数量 Q'ty	单价	
					¥	\$
1	B0089401120000000	GB894.1挡圈12	Circlip 12	1		
2	24303-I006-0000	CB125脚换档板弹簧	Gearshift Plate Spring	1		
3	24319-I006-0000	CB125脚换档板(五档国际档)	Gearshift Plate	1		
4	24301-I006-00000C	CB125脚换档轴组合(五档国际档 彩锌)	Gearshift Shaft ASSY	1		
5	24302-I008-0000	CG125D换档回位弹簧	Return Spring	1		
6	93301-51400520000	CB125脚换档臂垫圈14×0.5×20	Washer 14×0.5×20	2		
7	B0089401140000000	GB894.1挡圈14	CirClip 14	1		

8	24300-I006-00000C	CB125脚换挡臂部件(CB125脚 五国 彩锌)	Gearshift Lever ASSY	1		
9						
10						
11	24107-I006-0000	CB125脚拨叉轴	Gearshift Spork Shaft	1		
12	24104-I006-0000	CB125脚副轴右拨叉	Right Fork, Countershaft	1		
13	24106-I006-0000	CB125脚主轴拨叉	Center Fork, Mainshaft	1		
14	24105-I006-0000	CB125脚副轴左拨叉	Left Fork, Countershaft	1		
15	91126-I008-00000B	CG125D五星板紧固螺栓(白锌)	Bolt	1		
16	B0009300060000000	GB93弹垫6	Washer φ6	1		
17	24202-I006-0500	CB125脚五星板(五档国际档)	Stopping Plate	1		
18	B0011901040100000	GB119.1销4×10	Pin 4×10	1		
19	24213-I006-0500	CB125脚变速鼓(五档国际档)档显	Gearshift Drum	1		
20	24304-I006-0000	CB125脚定位板弹簧	Spring, Locating Plate	1		
21	2434A-I008-0000	CG125D定位板组合(短压板四/五档国际档)	Locating Plate ASSY	1		
22	B057830006002070B	GB5783螺栓M6×20(白锌)	Bolt M6×20	1		

### 磁电机总成 Magneto ASSY

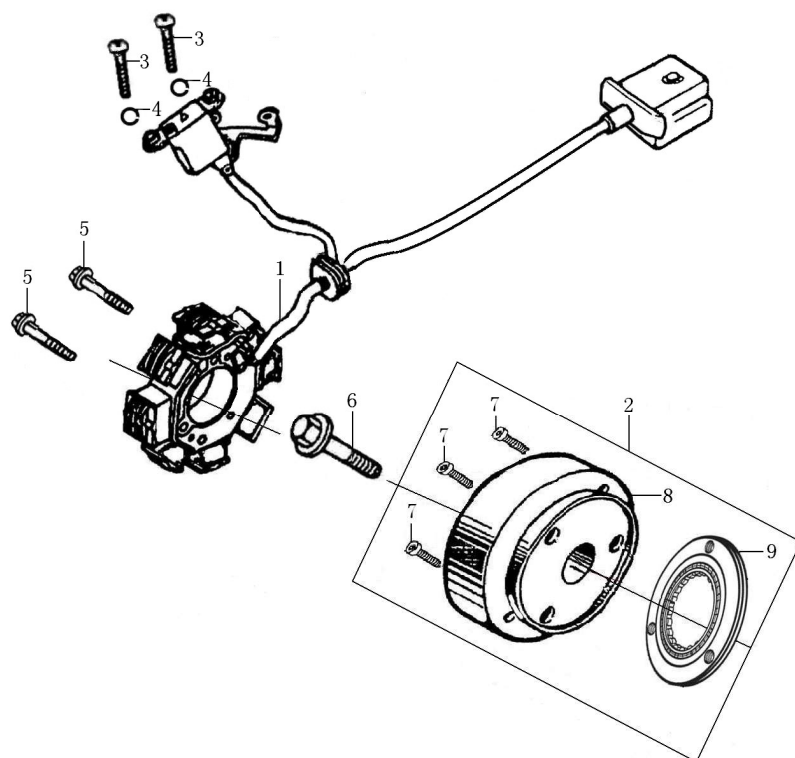

磁电机总成 MAGNETO COMP

序 NO	件号 Item Code	中文名称 Chinese	英文名称 Description	数量 Q' ty	单价 ¥	单价 \$
1	82120-IA27-000160	CB133磁电机定子组合[(12V12极三相全波直流) L1:600]接口G1	Stator ASSY, Magneto	1		
2	82130-IA27-0200	CB133磁电机转子组合(12V12极 带楔块分体式超离)	Rotor ASSY, Magneto	1		



3	B008230004001020B	GB823螺钉M4×10(白锌)	Screw M4×10	2		
4	B0009300040000000	GB93弹垫4	Washer φ4	2		
5	B166740A06002870B	GB16674小盘螺栓M6×28(白锌)	Bolt M6×28(white zinc)	2		
6	91106-I008-0000	CG125D磁电机安装螺栓M10×36	Magneto Mounting Bolt M10×36	1		
7	91197-I008-00000C	CG125D超越离合器紧固螺钉M8×18(彩锌)	Overrunning Bolt M8×18(color zinc)	3		
8	82130-I049-0301	CB125D-2#磁电机转子组合(12V8极 不带超越离合器)	Rotor ASSY, Magneto	1		
9	21300-LA73-0000	CG200-A水冷超越离合器部件(模块式)	Overrunning Clutch Assy	1		

## 电启动机构 Electrical Starter

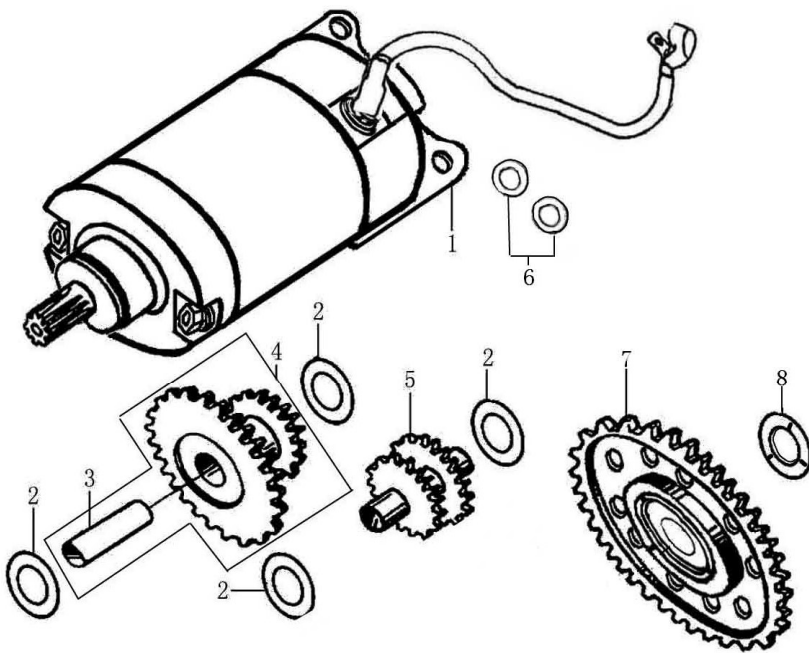

电启动机构  
ELECTRIC STARTING MECHANISM



序 NO	件号 Item Code	中文名称 Chinese	英文名称 Description	数量 Q'ty	单价	
					¥	\$
1	01020028	高压包（点火线圈）	Ignition Coil	1		
2	01020011	闪光器	Flasher	1		
3	10070007	喇叭	Horn	1		
4	01020025	整流器（电压调节器）	Voltage Regulator	1		
5	01020024	点火器（点火控制器）	Igniter	1		
6	01020027	起动继电器	Start Relay	1		

车架及后平叉 Frame and Rear fork

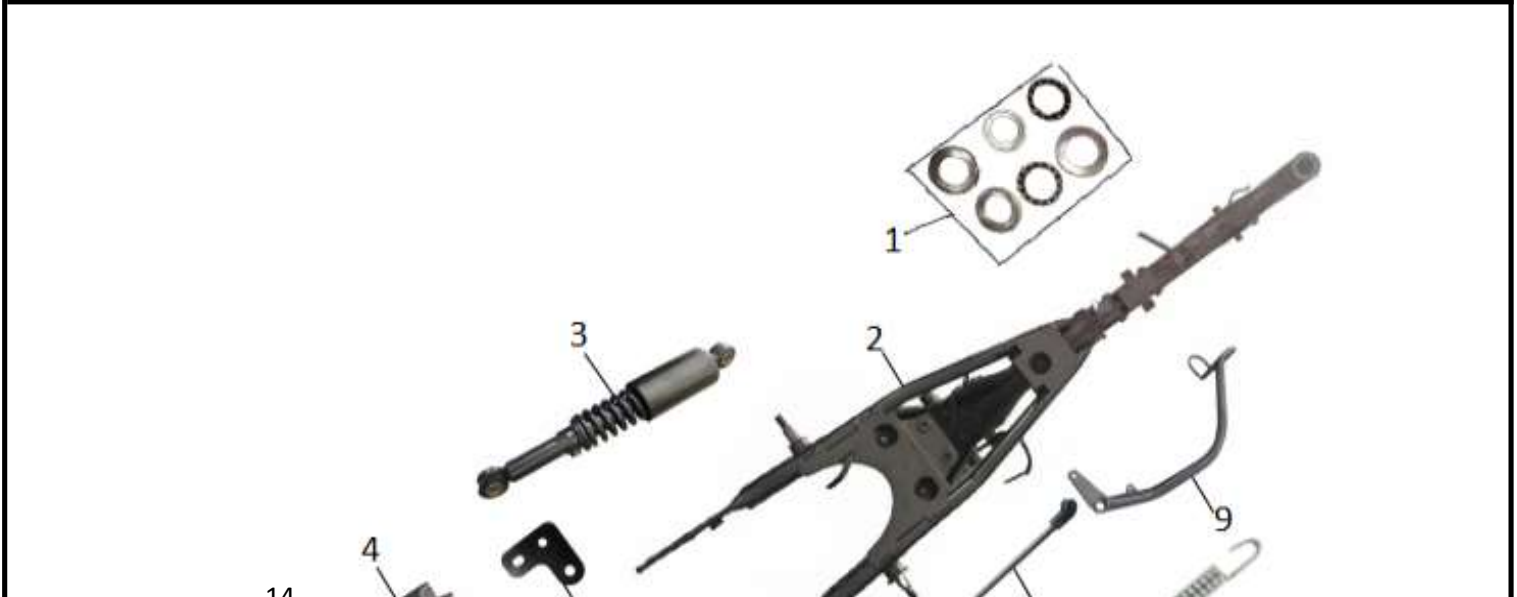

14

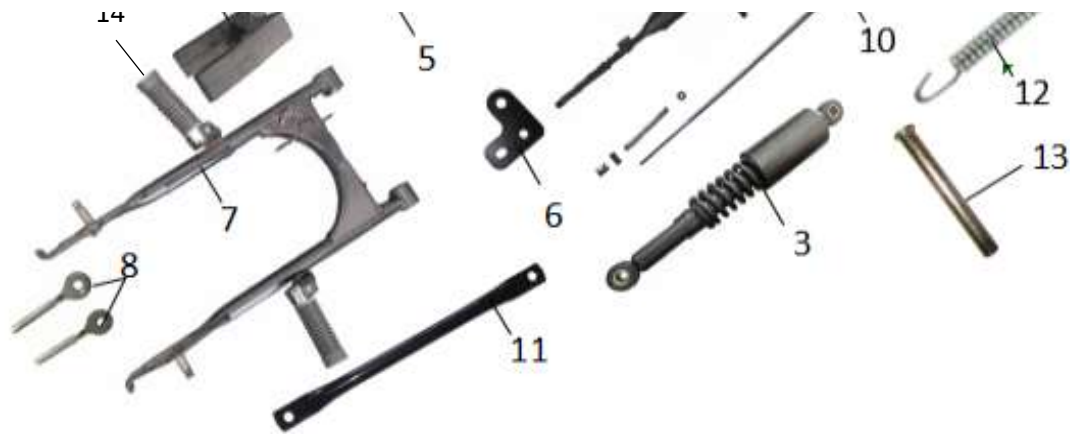

序 NO	件号 Item Code	中文名称 Chinese	英文名称 Description	数量		单价	
				Q' ty	¥	\$	
1	12030040-2	钢碗		1			
2	0201-250RTD	车架	Frame	1			
3	07010171	后减震		2			
4	06020170-3	平叉链托	Rubber Stand Of Chain	1			
5	02011860-1	后转向灯支架左		1			
6	02011860-2	后转向灯支架右		1			
7	02011849	后平叉	Rear Fork	1			
8	02011856	调链器		2			
9	02011857	后刹车踏板		1			
10	02011858	后刹车拉杆		1			
11	02011854	扭力杆		1			
12	07020118	后制动踏板回位弹簧		1			
13	15010049	双撑轴		1			
14	02050065	后搁脚		1付			

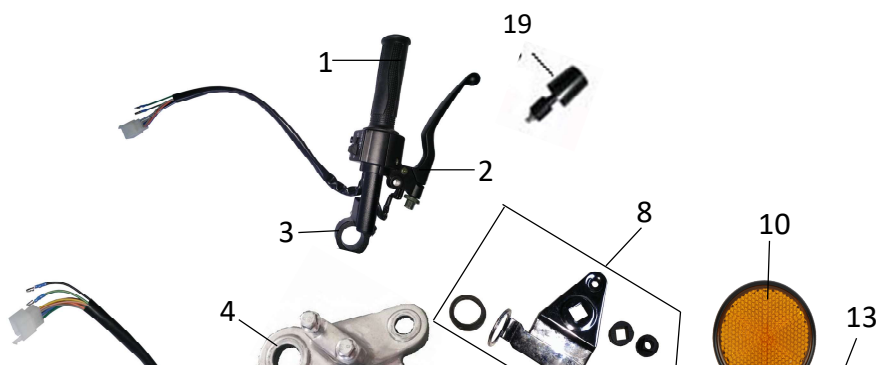

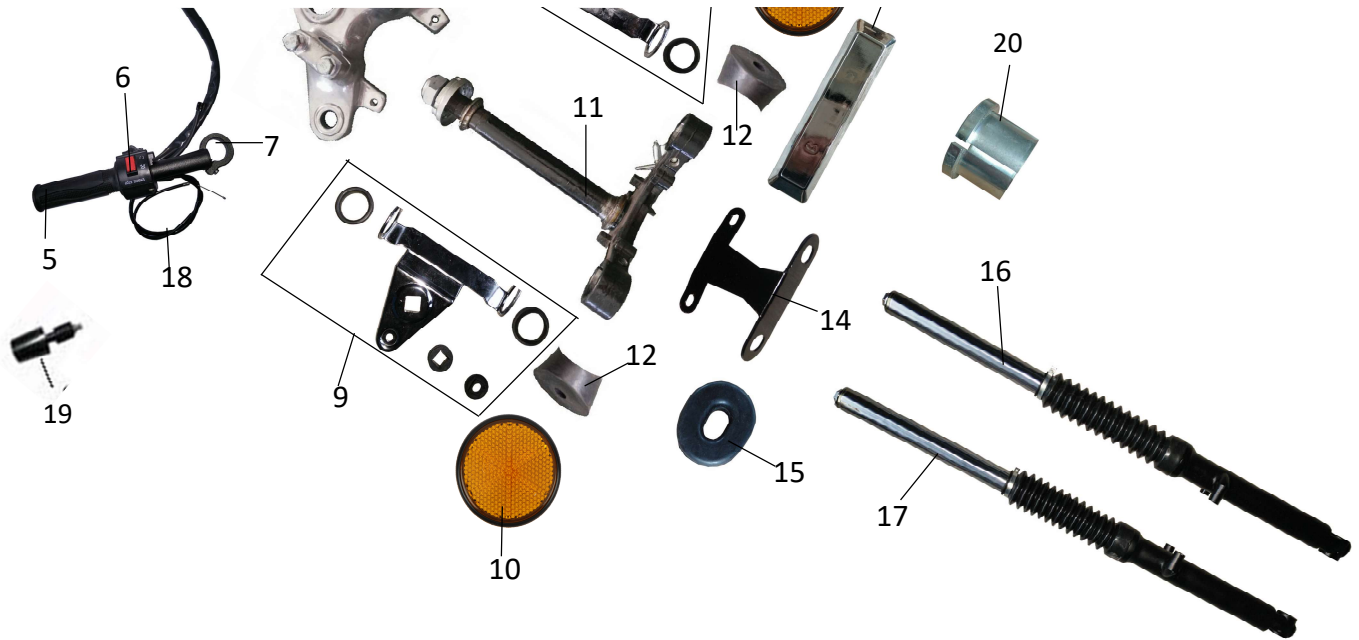

序 NO	件号 Item Code	中文名称 Chinese	英文名称 Description	数量			单价	
				Q'ty	¥	\$		
1	10020061	左把套		1				
2	10010121-1	左组合开关		1				
3	02030761-1	方向把左		1				
4	02030760	上联板		1				
5	10020060	油门把套		1				
6	10010121-2	右组合开关		1				
7	02030761-2	方向把右		1				
8	02011861-1	大灯支架左		1				
9	02011861-2	大灯支架右		1				
10	09050003-2	圆橙色反光片M6		2				
11	02030759	方向柱		1				
12	06020170-7	前反光片装饰橡胶		2				
13	03040079	前标牌		1				
14	02011859	前标牌支架		1				
15	06020170-4	侧板椭圆小橡皮		2				
16	07010171-1	前减震左		1				
17	07010171-2	前减震右		1				
18	08020274	油门线		1				
19	10020062	平衡块	Counterbalance Block	2				
20	14020660	前减震转换套		2				

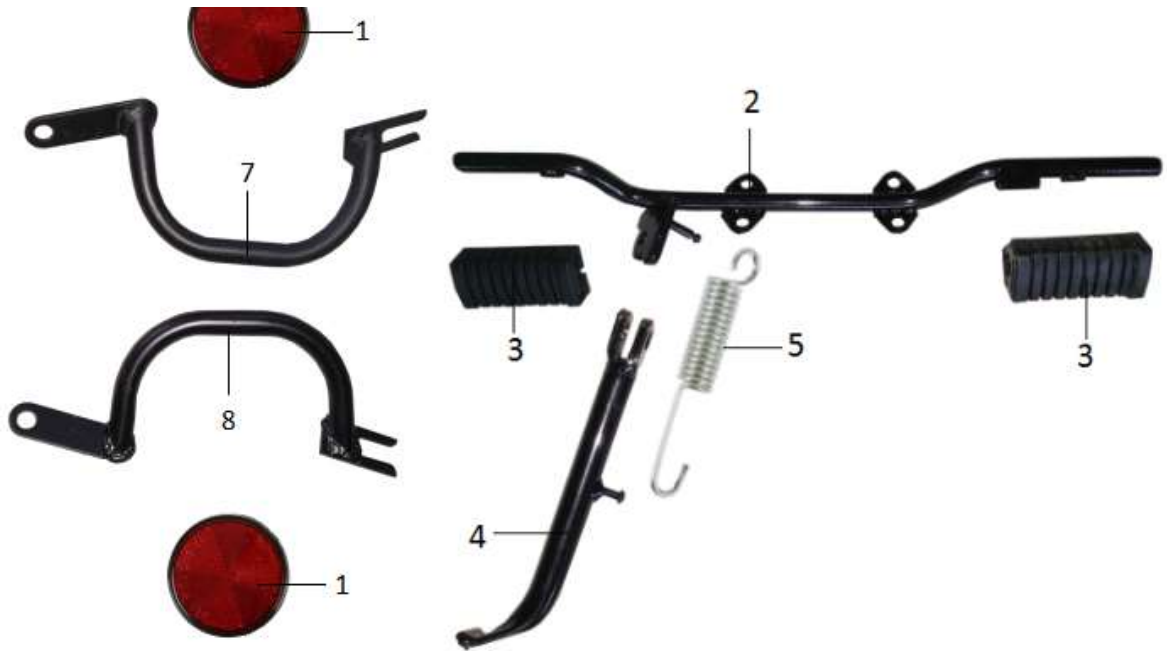

序 NO	件号 Item Code	中文名称 Chinese	英文名称 Description	数量			单价	
				Q' ty	¥	\$		
1	09050002-3	圆红色反光片M6		2				
2	02011852	搁脚架		1				
3		脚踏橡胶		2				
4	02011853	单撑（带螺栓）		1				
5	07020117	单撑弹簧		1				
6	02011864-1	后护手左		1				
7	02011864-2	后护手右		1				

轮胎、轮毂



序 NO	件号	中文名称	英文名称	数量	单价	
	Item Code	Chinese	Description		Q' ty	¥
1	06010093	前轮内胎（含垫带）4.00-17		1		
2	06010094	后轮内胎（含垫带）5.00-15		1		
3	02040355	前网轮总成（2.15-17）		1		
4	06010095	前轮外胎4.00-17		1		
5	06010096	后轮外胎5.00-15		1		
6	02040356	后网轮总成2.50-15		1		
7	12050007-2	轴用卡簧58		1		
8	02040354	牙盘428-38T		1		

碟刹 Front Brake



序 NO	件号	中文名称	英文名称	数量 Q'ty	单价	
	Item Code	Chinese	Description		¥	\$
1	04010110	前碟刹总成	Front Disc Brake ASSY	1		
2	04030006	后毂盖		1		



消声器 Muffler



序 NO	件号	中文名称	英文名称	数量	单价	
	Item Code	Chinese	Description	Q'ty	¥	\$
1	01050087	消声器筒体（带垫）	Muffler	1		

仪表、管线 Wires and Cable



序 NO	件号	中文名称	英文名称	数量	单价	
	Item Code	Chinese	Description	Q'ty	¥	\$
1	10050084	仪表	Speedmeter	1		
2	08020273	离合器线	Clutch Cable	1		
3	10080055	套锁		1		
4	08010137	电缆	Wire harness	1		
5	10040090	计速器		1		
6	08020276	里程线		1		
7	07020007	刹车开关拉簧	Spring of the Brake switch	1		
8	10010035	刹车开关	Brake Switch	1		

橡胶品 Rubber Accessories



序 NO	件号	中文名称	英文名称	数量	单价	
	Item Code	Chinese	Description	Q' ty	¥	\$
1	01040042	空滤器	Air Cleaner	1		
2	06990001	二级过滤器	Second Filter	1		
3	06990044	废气管		1		
4	06030002	汽油管	Fuel Pipe	18cm		
5	06020170-6	后泥板（穿线）橡胶垫		2		

6	06020170-11	电瓶扎带	Battery Strap	1	
7	09060017	后视镜QY181	Rearview Mirror	1	
8	02040357	链条（428H-104）	Chain 428H-104	104节	

油箱、坐垫 Gas Tank & seat



序	件号	中文名称	英文名称	数量	单价
---	----	------	------	----	----

NO	Item Code	Chinese	Description	Q' ty	¥	\$
1	05030074	油箱	Fuel Tank	1		
2	06020170-1	油箱前缓冲皮	Rubber Stand Of Fuel Tank	2		
3	06020170-2	油箱后缓冲橡胶		1		
4	10060005	油箱开关	Switch of Fuel	1		
5	12010007	油管夹8.8	Pipe Clip 8.8	4		
6	12010022	钢丝卡子14		1		
7	12010023	钢丝卡子15.3		1		
8	05010083	坐垫	Rear Seat	1		

塑件、灯具



序 NO	件号 Item Code	中文名称 Chinese	英文名称 Description	数量 Q'ty	单价	
					¥	\$
1	09020149	前转向灯左		1		
2	09020150	前转向灯右		1		
3	09020151	后转向灯左		1		
4	09020152	后转向灯右		1		
5	09030083	后尾灯		1		
6	06020170-5	穿线（里程线）橡胶垫		1		
7	03010670	前泥板		1		
8	09010090	前大灯		1		
9	06020170-8	后泥板与车架连接工字型橡胶（后）		2		
10	06020170-6	后泥板（穿线）橡胶垫		2		
11	03010669	后泥板		1		
12	06020170-9	车架与后泥板连接橡胶件		2		
13	03030966	后泥板前段		1		
14	06020170-10	侧板椭圆大橡皮		4		
15	03010666	护板左		1		
16	03010667	护板右		1		
17	06020170-4	侧板椭圆小橡皮		4		
18	03030967	链罩		1		

### 工具包 Tool Kit



序号 NO	件号	中文名称	英文名称	数量	单价	
	Item Code	Chinese	Description	Q'ty	¥	\$
1	16010005	12-14开口扳手	Open Spanner(12-14)	1		
2	16010004	8-10开口扳手	Open Spanner (8-10)	1		
3	16010006	双头螺丝刀	Dual-purpose Screwdriver	1		
4	16010008	18对边火花塞套筒	Spark Plug Box Spanner (S=18)	1		
5	16010002	6mm内六角扳手	Socket Head Screw Wrench(6mm)	1		
6	10990006	电瓶 (12V6. 5A)	Battery	1		